

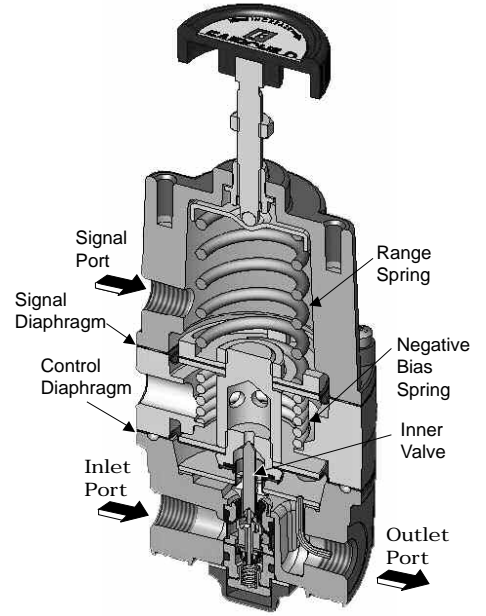

Features

- Control sensitivity of 1/2" water column allows use in precision applications.
- A balanced Supply Valve minimizes the effects of supply pressure variation.
- An Aspirator Tube minimizes downstream pressure droop under flow conditions.
- A separate Control Chamber isolates the diaphragm from the main flow to eliminate hunting and buzzing.
- Mounting Bracket is available
- Canadian Registration Number (CRN) certification for all territories and provinces.



Operating Principles

The output of the relay is the sum of the spring bias, set with the Range Screw, plus a pneumatic input signal. ($P_o = P_s \pm K$); where P_o is output pressure, P_s is signal pressure, and K is the combined spring constant. The signal pressure exerts a force against the top of the Signal Diaphragm that creates a downward force on the Diaphragm Assembly and opens the Supply Valve. Output pressure flows through the Outlet Port and the Aspirator Tube to the Control Chamber where it creates an upward force on the bottom of the Control Diaphragm.

When the setpoint is reached, the force that acts on the bottom of the Control Diaphragm balances with the force that acts on the top and bottom of the Signal Diaphragm.

When the output pressure increases above the setpoint, the increase is transmitted through the Aspirator Tube to the Control Diaphragm. The increased pressure that acts on the Control Diaphragm moves the Diaphragm Assembly upward to seat the Supply Valve, move the Relief Seat away from the Relief Valve, and let downstream air exhaust through the port in the Ring Spacer.

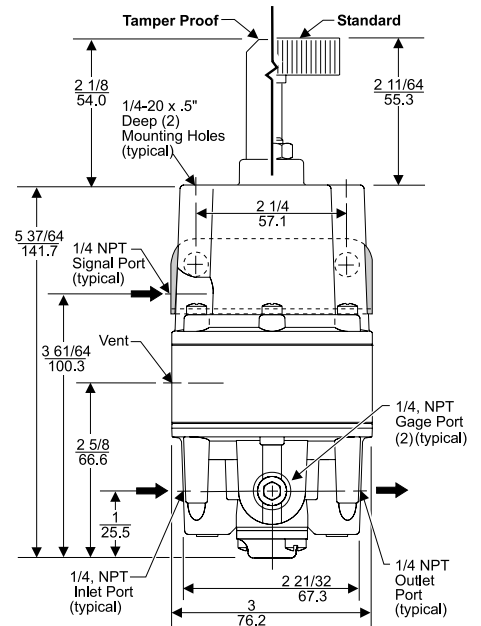

D
Model
14

The Model 14 Positive and Negative Bias Relay is designed for applications that require an output pressure that is the sum of a controlled input signal plus or minus a fixed bias.

Technical Information

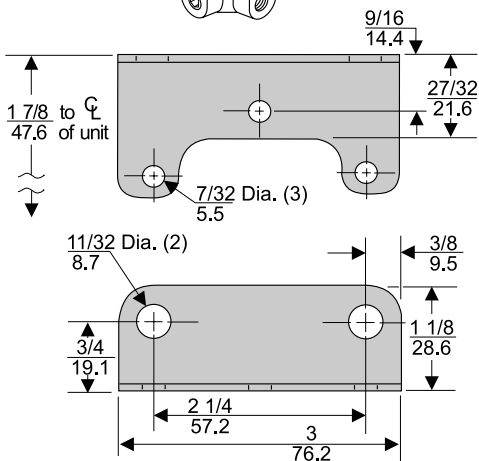
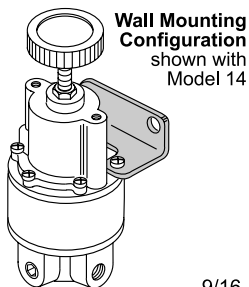
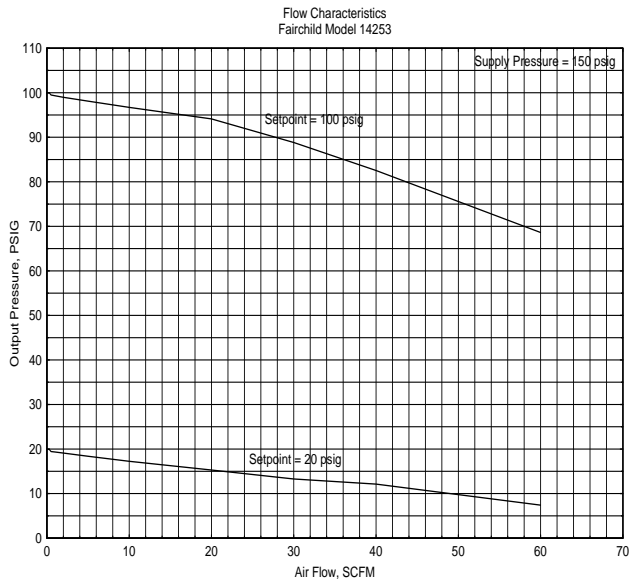

Mounting Bracket: 09921

Model 14 Relay Kits & Accessories

Mounting Bracket Kit.....09921 (sold separately)

Service Kit

A Service Kit is available for the Model 14, refer to the *Fairchild Model 14 Positive / Negative Bias Relay Instruction, Operation and Maintenance Instructions, IS-30000014*.

Catalog Information

Catalog Number

1 4 2

Pressure Range

psig	[BAR]	(kPa)
-18 to 2	[-1.2 to .15]	(-120 to 15)
-18 to 10	[-1.2 to .7]	(-120 to 70)
-18 to 30	[-1.2 to 2]	(-120 to 200)
-18 to 100	[-1.2 to 7]	(-120 to 700)

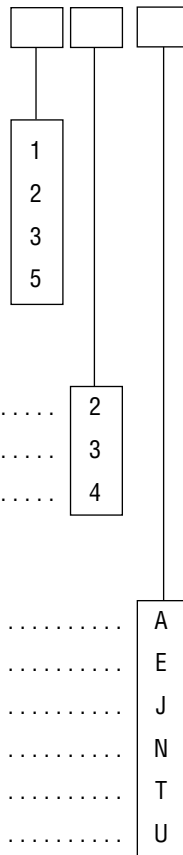

Pipe Size

1/4" NPT	2
3/8" NPT	3
1/2" NPT	4

Options

Silicone Elastomers ¹	A
Tapped Exhaust	E
Fluorocarbon Elastomers	J
Non-Relieving	N
Tamper Proof	T
BSPT (Tapered)	U

¹ Maximum Supply Pressure 75 psig, [5.0 BAR], (500 kPa)

Specifications

Supply Pressure

250 psig, [17.0 BAR], (1700 kPa) Maximum

Flow Capacity (SCFM)

40 SCFM (68 m³/HR) @ 100 psig, [7.0 BAR], (700 kPa) supply and 20 psig, [1.5 BAR], (150 kPa) setpoint

Exhaust Capacity (SCFM)

5.5 SCFM (9.35 m³/HR) where downstream pressure is 5 psig, [.35 BAR], (35 kPa) above 20 psig, [1.5 BAR], (150 kPa) setpoint

Signal or Output Pressure

150 psig, [10.0 BAR], (1000 kPa) Maximum

Supply Pressure Effect

Less than 0.1 psig, [.007 BAR], (.7 kPa) for 100 psig, [7.0 BAR], (700 kPa) change in supply pressure

Sensitivity

Less than 1/2" (1.27 cm) Water Column

Ambient Temperature

-40°F to +200°F, (-40°C to 93.3°C)

Hazardous Locations

Acceptable for use in Zones 1 and 2 for gas atmosphere; Groups IIA and IIB and Zones 21 and 22 for dust atmospheres.

Materials of Construction

Body and HousingAluminum
TrimStainless Steel, Brass, Zinc Plated Steel
Diaphragms.....Nitrite on Dacron



Model 14

P.S.I. Supplies Pty Ltd

Catalogue extract for:

Fairchild Model 14 Positive and Negative Bias Relay

For further information or sales information please contact:

www.psisupplies.com.au

Ph: +61 3 9899 6444 Email: sales@psisupplies.com.au