



Features

- Outstanding sensitivity
- Droop or boost virtually eliminated
- Fast response
- Minimal effect for supply pressure change
- High forward flow capacity
- High exhaust capacity
- Small physical size, saves space
- Sapphire orifice
- Permits use in instrumentation and control applications
- Provides constant output pressure over large flow range
- Eliminates output pressure excursions
- Reduces time to exhaust
- Reduces abrasive effects of air

Operating Principles

This Model 81 is a precision two-stage regulator that combines a pilot control system with a basic force balance system to provide accurate output pressure regulation.

It is recommended for use in both highly sensitive instrumentation and control circuits and in equipment requiring high flow with precise control.

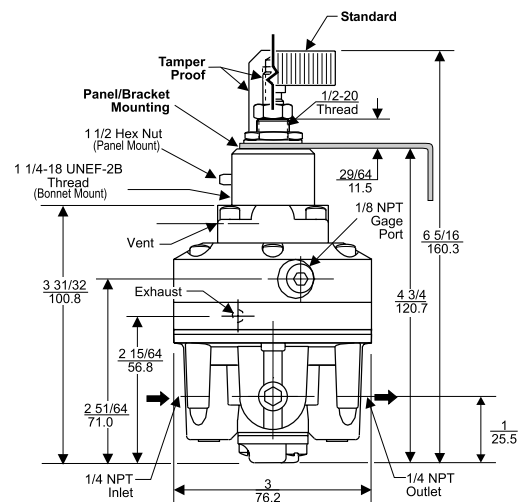
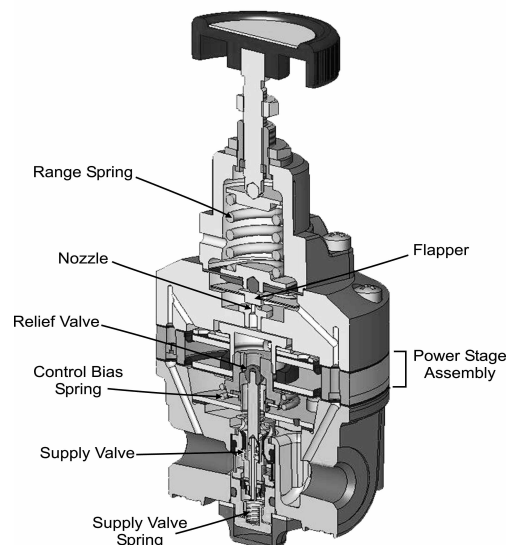

P.S.I. Supplies Pty Ltd

Catalogue extract for:

Fairchild Model 81 Multi-Stage Pressure Regulator

For further information or sales information please contact:

www.psisupplies.com.au

Ph: +61 3 9899 6444 Email: sales@psisupplies.com.au