

# INSTRUCTIONS FOR THE INSTALLATION, OPERATION AND MAINTENANCE FOR FAIRCHILD MODEL 100 PNEUMATIC PRESSURE REGULATOR

## GENERAL INFORMATION

The Model 100 is a spring opposed, diaphragm operated, pressure regulating valve with a large flow capacity.

### Specifications Model 100

Flow Capacity ..... in excess of 3000 SCFM  
 150 psig [10 BAR] (1000 kPa) (5100 m<sup>3</sup>/H-R)  
 supply; 40 psig [2.8 BAR] (1½ NPT Conn.)  
 (280 kPa) set

Exhaust capacity ..... 4 SCFM (74.8 m<sup>3</sup>/H-R)  
 downstream pressure 5 psig  
 [.35 BAR] (35 kPa) above set pressure

Sensitivity ..... ½" W.C. (1.27 cm)

Effect of supply pressure variation ..... Less than 0.1 psig  
 [.007 BAR] (.7 kPa)  
 for 100 psig [7.0 BAR] (700 kPa) change

Maximum supply pressure ..... 250 psig  
 [17 BAR] (1700 kPa)

Ambient Temperature Limits ..... -40°F to +200°F  
 (-40°C to 93.3°C)

## PRINCIPLES OF OPERATION

With supply pressure turned off, and the control knob turned to allow the range spring to be expanded, the supply valve and relief valve are seated. When supply air is introduced to the inlet port, it exerts pressure against the supply valve and is simultaneously transmitted through the channel in the supply valve, exerting pressure on the bottom of the balance diaphragm. When the knob of the regulator is adjusted to a specific set point, it compresses the range spring, which exerts a force against the top of the control diaphragm. As the diaphragm moves downward, the force transmitted by means of the exhaust tube opens

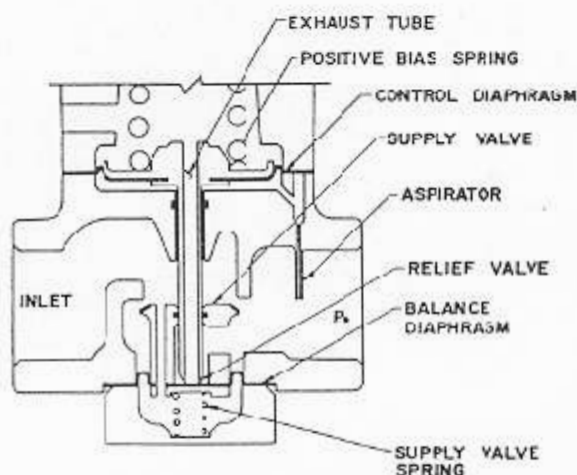
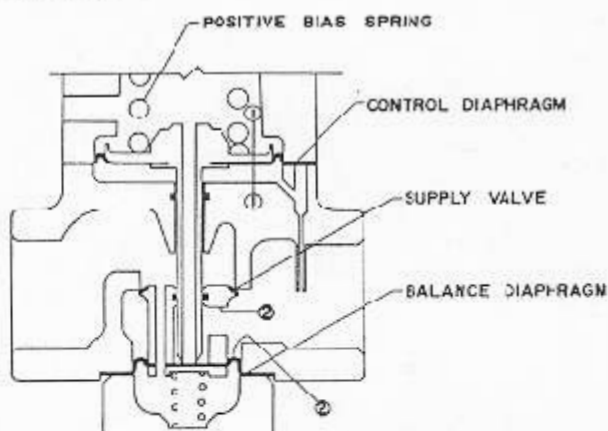

the supply valve, allowing supply air to be routed to the outlet port. Outlet (downstream) pressure is transmitted through the aspirator to the underside of the control diaphragm. The force due to downstream pressure acting upward on the bottom of the control diaphragm, aided by the supply valve spring force, acts against the range spring force exerted downward on the top of the control diaphragm, so that these forces are in balance and  $P_o = K$  where  $P_o$  is output pressure and  $K$  is spring constant. This condition is not reached until output pressure reaches the desired set point. Until then, the downward force opens the supply valve, allowing supply air to be routed to the outlet port. The increase

in pressure on the bottom of the control diaphragm causes it to move upward against the range spring force, allowing the supply valve to throttle and maintaining output pressure.

When set point is reached, the force acting on the bottom of the control diaphragm is in balance with the force acting on the top of the diaphragm. At this point the force (1) due to pressure acting on the bottom of the control diaphragm is equal to the force (1) due to the range spring acting on the top of the control diaphragm. The force (2) due to downstream pressure act-

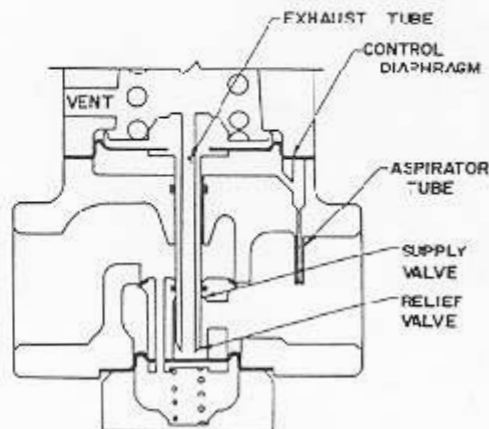

ing on the top of the supply valve is balanced by force (2) due to downstream pressure acting on the bottom of the balance diaphragm. If the downstream pressure increases, the increased pressure will be sensed on the underside of the diaphragm through the aspirator tube, and the diaphragm will move upward, seating the supply valve. As the diaphragm continues to move

upward, it opens the relief valve, and air is exhausted through the exhaust tube and a vent in the bonnet. If downstream pressure decreases, the diaphragm will move downward, closing off the bottom of the exhaust tube and the relief valve, eventually opening the supply valve. This throttling action continues until forces are again in balance.

## INSTALLATION

### NOTICE

The presence of certain diester oils in the airlines may hasten deterioration of the elastomers and thus decrease the useful life of this unit.

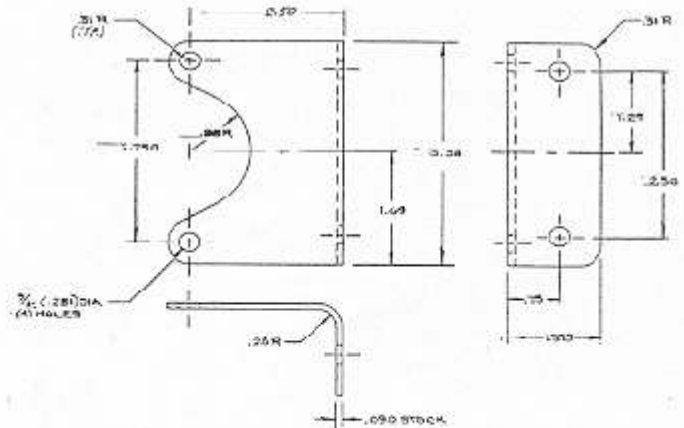
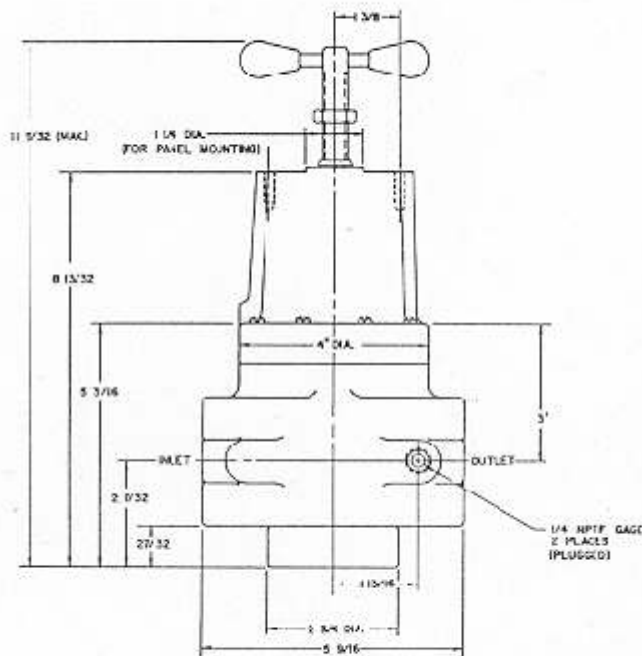

Clean all pipe lines to remove dirt and scale before installation is made. Apply minimum amount of pipe compound to male threads of air line only. Start with third thread back and work away from end of line to avoid possibility of getting compound into regulator. Install regulator in air line; body is fitted with a 3/4" 1", 1 1/4", or 1 1/2" NPT for inlet and outlet connections. Regulator can be mounted in any position without affecting its operation. Inlet and outlet connections are labelled (look for arrows denoting direction of flow on underside of unit) and should be tightened securely. Avoid undersized fittings that will limit flow through the regulator and cause pressure drop downstream. The use of a filter to remove dirt and entrained liquid in the air line ahead of the regulator is recommended for best performance. If an air line lubricator is used, it should be located downstream beyond the regulator in order to avoid interference with the regulator performance.

## ADJUSTMENTS

No field adjustments are required.

## OPERATION

Relieve pressure on range spring before putting regulator into service for the first time. To operate, turn the adjusting screw slowly in a clockwise direction until required downstream pressure is obtained. Turned in

this direction, the screw compresses the range spring causing increased output pressure. For decreased output pressure, turn the screw counterclockwise.

## SERVICE KIT INSTALLATION

### For Standard Unit

1. Check parts in the EA-( )-( ) service kit against parts marked with an asterisk in the exploded view and the associated table.
2. Mark Bonnet Assembly (6) and Body (15) so that they can be reassembled correctly.
3. Loosen Nut on Handle Assembly (1) and turn Handle so that pressure on Spring (8) is relieved.

### For Tamper Proof Unit

1. Check parts in the EA-( )-( ) service kit against parts marked with an asterisk in the exploded view and the associated table.
2. Mark Bonnet Assembly (6) and Body (15) so that they can be reassembled correctly.
3. Remove Cap (1A), loosen Nut (1C) and turn screw (1B) so that pressure on Spring (8) is removed.

### For All Units

4. Remove eight Screws (9) holding Bonnet Assembly (6) to Body (15) and set aside Bonnet Assembly (6).
5. Remove and set aside, Spring Seat Assembly (7), Spring (8) and Lower Spring Seat (30).
6. Remove Piston Assembly (14) and discard.

### CAUTION

Note for Step 7: retainer (24) is under compression by Spring (25) of the Valve Assembly (23).

7. Carefully remove screws (9) holding retainer (24) to Body Assembly (15), releasing each screw a few turns at a time. Set Retainer (24) aside.
8. Remove Spring (25) and set aside. Remove Valve Assembly (23) and discard.

9. Secure Valve Assembly (23) from service kit and place into bottom well of Body Assembly (15), making sure that cross hole on Valve Assembly (23) lines up with Output port of Body Assembly (15) and that six mounting holes in diaphragm (20) are lined up with six bolt holes in Body Assembly (15).
10. Place Spring (25) into Plate (21) of Valve Assembly (23). Carefully position Retainer (24) over Diaphragm (20) and tighten opposite screws (9) one at a time until Retainer (24) is flush with body Assembly (15).
11. Secure Piston Assembly (14) from service kit and drop into top center hole of Body Assembly (15).
12. Align eight holes in Diaphragm (13) with eight holes in Body Assembly (15), making sure that the extra hole in Diaphragm (13) is NCT aligned with the hole in Body (15) which is directly over the Output port of the regulator.
13. Place a light coat of Molycote G-N paste over nut (11) of the Piston Assembly (14). Place Spring Seat (30) on top of the Nut (11) on Piston Assembly (14).
14. Place Spring (8) and Spring Seat Assembly (7) over Lower Spring Seat (30). The ball on Spring Seat Assembly (7) should be facing up.
15. Align marks on Body Assembly (15) and Bonnet Assembly (6) made in Step 2. Tighten opposite screws (9) in Bonnet Assembly (6) to secure Bonnet Assembly (6) to Body Assembly (15).
16. Reinstall the regulator in accord with instructions in the IDM and follow instructions in the Operation section for placing the regulator back in service.

## OPTIONS

Body Assembly	1 NPTF	1 ½ NPTF	E	N	T
10 psig	* EB-10035-6	EB-10035-8			
30, 60, 100, 150 psig	EB-10035-2	EB-10035-4			
Bonnet Assembly	EB-10036-3	EB-10036-3	EB-10036-5	EB-10036-3	
Piston Assembly	EB-10027-2	EB-10027-2	EB-10027-2	EB-10478	
Valve Assembly	EB-10028-3	EB-10028-3	EB-10028-1	EB-10028-3	
Cap	N/A	N/A	N/A		EB-10307
Set Screw	N/A	N/A	N/A		EB-10309
Nut	N/A	N/A	N/A		EB-10050
Gasket	N/A	N/A	N/A		EB-11906

N/A — Not Applicable

All numbers are prefixed by EB-

## MAINTENANCE

The regulator is easily disassembled for the occasional cleaning or removal of foreign matter. Before this is done, however, shut off valve upstream of the regulator to prevent escape of air when regulator is disassembled. There is no need to remove the regulator from the pipe line; remove the six No. 10-32 screws on the bottom of the unit and pull out the inner valve assembly. Wash inner valve assembly with solvent exercising care to avoid damaging diaphragms and

valve facings. Replace assembly carefully. The vent hole in the bonnet should be kept clear. A slight flow of air through this hole is necessary for the proper operation of the regulator. The adjusting screw should be lubricated with Molycote type "G" grease.

### CAUTION

(Avoid such solvents as acetone, carbon tetrachloride, trichlorethylene)

## TROUBLE SHOOTING

PROBLEM	CHECK
Leakage	Body screw tightness, Diaphragm
High Bleed	Relief pintle and relief seat for damage or contamination
Difficult to Adjust	Adjusting screw and ball Seal ring lubrication

## REPAIR PARTS LIST

A Service Kit is available for maintenance of the Model 100:

Standard	EA-12150-1
Non-Relieving	EA-12168
Tamper Proof	EA-12164

**STANDARD**

**TAMPER PROOF**

Index	Part No.	Description
1	EB-10106	Handle Assembly
1 A	EB-10307	Cap
1 E	EB 10309	Set Screw
1 C	EB-10053	Nut
1 D	EB-11906	Gasket
6	See Table	Bonnet Assembly
7	EB-10037	Spring Seat Assembly
8	EB-10022-	Spring
9	EB-1032-20	Screw #10-32 x 1 1/4 LG
9 A	EB-10502	Washer
12	EB-10192	Piston
13	E3-13461	Diaphragm
*14	See Table	Piston Assembly
15	EB-10035	Body Assembly
*23	See Table	Valve Assembly
24	EB-10019	Retainer
25	FR-10141	Spring
30	EB-14571	Spring Seat Lower

**Service Kit Components**

Option	Suffix
Tamper Proof	T
Tapped Exhaust	E
Non-Relieving	N

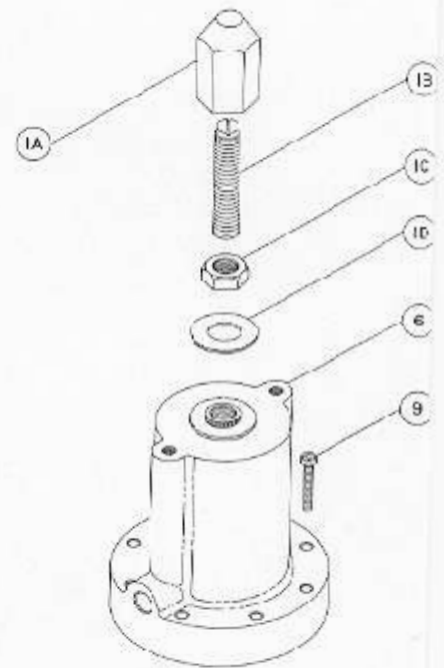
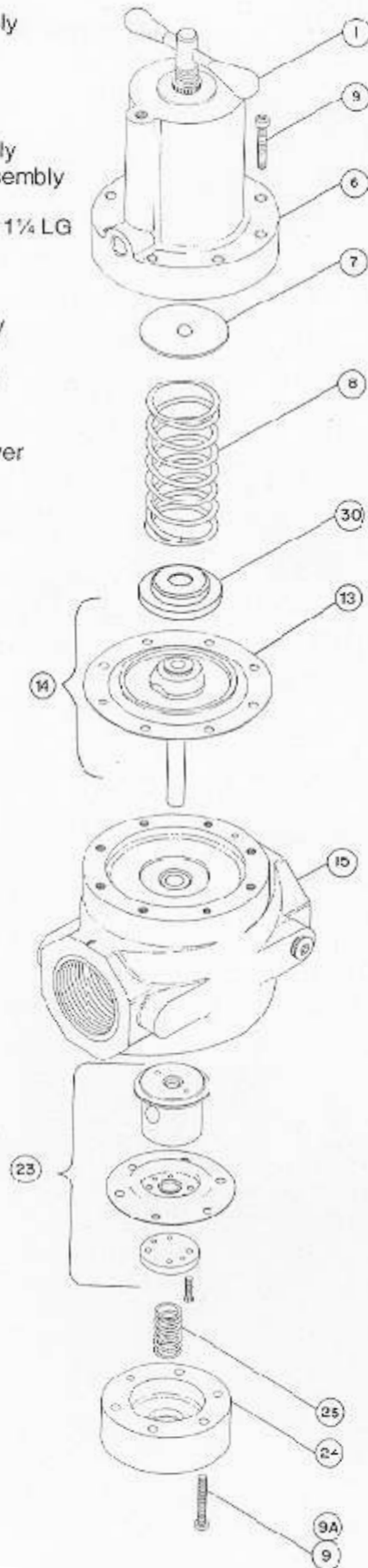

# **P.S.I. Supplies Pty Ltd.**

Installation and Maintenance Instructions for:

## **Fairchild Model 100 Pneumatic Pressure Regulator**

For further advice or assistance please contact:

[www.psisupplies.com.au](http://www.psisupplies.com.au)

Ph: +61 3 9899 6444

Email: [sales@psisupplies.com.au](mailto:sales@psisupplies.com.au)