

# INSTALLATION, OPERATION AND MAINTENANCE INSTRUCTIONS FOR THE FAIRCHILD MODEL 25 REVERSING RELAY

## GENERAL INFORMATION

The Model 25 reversing relay provides an output that decreases in direct proportion to the increase in signal pressure.

### Specifications

#### Model 25

Flow capacity ..... 40 SCFM (68 m<sup>3</sup>/HR)  
(100 psig [7.0 BAR] (700 kPa) supply,  
20 psig [1.5 BAR] (150 kPa) set)

Exhaust capacity ..... 11 SCFM (18.7 m<sup>3</sup>/HR)  
Downstream pressure 5 psig  
[.35 BAR] (35 kPa) above set point

Sensitivity ..... 1/8" (0.31 cm) W.C.

Effect of supply ..... Less than 0.1 psig  
pressure variation ..... [.007 BAR] (.7 kPa)  
for 100 psig [7.0 BAR]  
(700 kPa) change

Supply pressure ..... 250 psig [17.0 BAR]  
(1700 kPa) max.

Signal pressure ..... 150 psig [10.0 BAR]  
(1000 kPa) max.

Output pressure ..... 150 psig [10.0 BAR]  
(1000 kPa) max.

Ambient temperature ..... -40°F to +200°F  
-40°C to 93.3°C

## PRINCIPLES OF OPERATION

When the adjusting screw of the Model 25 relay is turned for a specific set point, the positive bias spring exerts a force against the top of the diaphragm assembly.

Signal  $P_s$  exerts pressure against the top of the positive signal diaphragm and against the bottom of the negative signal diaphragm. For the Model 25, the combined force is the sum of  $P_s$  acting on the negative signal diaphragm, which has twice the effective area of the positive signal diaphragm, in the upward direction, and on the positive signal diaphragm in the downward direction, plus the positive bias spring force acting in a downward direction on the diaphragm assembly.  $P_o$  equals  $K - 2P_s + P_s$  or  $P_o$  equals  $K - P_s$  where  $P_o$  is output pressure,  $P_s$  is signal pressure, and  $K$  is the spring constant.

This condition is achieved only when output pressure reaches the desired set point. Until then, the diaphragm assembly moves downward, causing the supply valve to open and supply air to be routed to the outlet port.

Increased pressure on the control diaphragm causes the diaphragm assembly to move upward against the force of the signal pressure acting on the positive signal diaphragm and the positive bias spring force acting on the top of the negative signal diaphragm, aided by the signal pressure acting on the bottom of the negative signal diaphragm and the supply valve spring force.

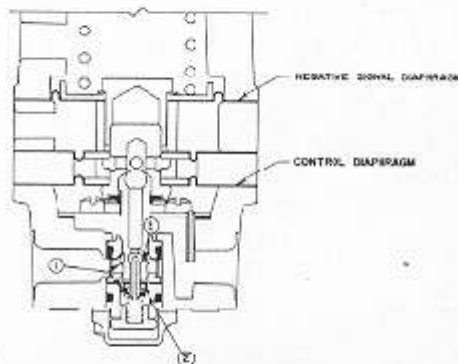
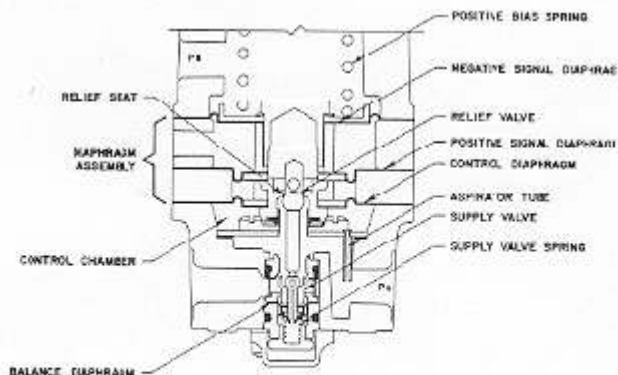

This force acting through the pirtle allows the supply valve to throttle, maintaining output pressure. Downstream pressure is also transmitted up the center tube to the upper side of the upper balance diaphragm and down the tube to the underside of the inner valve assembly balance diaphragm. When set point is reached, the supply valve throttles, keeping the forces acting on the bottom and top of the diaphragm assembly balanced.

If downstream pressure increases above set point, the increase is transmitted through the aspirator tube to the control diaphragm, moving the assembly upward and allowing the supply valve to be seated. As the diaphragm assembly continues to move upward, sliding on the seal tube, the relief valve seat moves away from the relief valve and the upper balance diaphragm assembly moves away from the pintle tube.

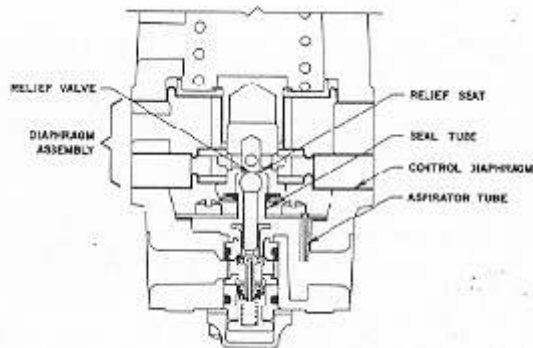

If downstream pressure decreases below set point, the decrease is transmitted through the aspirator tube and sensed by the control diaphragm. Decreased pressure on the lower diaphragm causes it to move downward, closing off the end of the relief pintle tube and lowering the relief seat against the pintle. As the diaphragm continues to move downward, it opens the supply valve and increases downstream pressure until set point value is reached.

## INSTALLATION

Clean all pipe lines to the regulator to remove dirt and scale before installation is made. Apply minimum amount of pipe compound to male threads of air line only. Start with third thread back and work away from end of line to avoid possibility of getting compound into relay. Install relay in air line; body is fitted with a 1/4", 3/8" or 1/2" NPT for inlet and outlet connections. Relay can be mounted in any position without affecting its operation. Inlet and outlet connections are labeled (look for arrows, denoting direction of flow on underside of unit) and should be tightened securely. Avoid undersized fittings that will limit flow through the relay and cause pressure drop downstream. The use of a filter to remove dirt and entrained liquid in the air line ahead of the relay is recommended for best performance. If an air line lubricator is used, it should be located downstream beyond the relay in order to avoid interference with the relay performance.

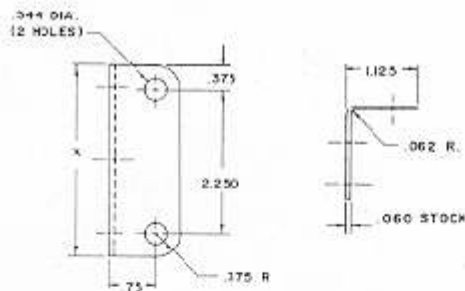

Mounting Bracket EB-09921

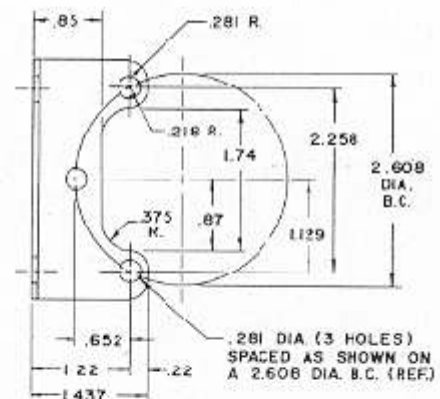
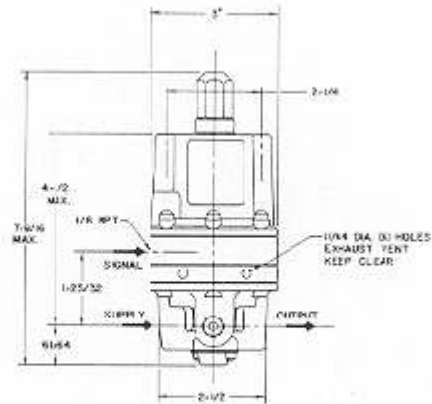

## SERVICE KIT INSTALLATION

### Model 25

1. Check parts in service kit EA-12136 against items marked with an asterisk in the table and the exploded view.
2. Mark bonnet (3) ring spacers (8) and (10) and body (14) so that unit may be reassembled properly.
3. Remove cap nut (1) and set aside.
4. Turn range screw (1A) to release compression on spring (6).
5. Remove six screws (4) securing bonnet assembly (3) to ring spacers (8) and (10) and body (14).
6. Remove bonnet assembly (3) and set aside.
7. Remove spring seat (5) and spring (6) and set aside.
8. Remove diaphragm assembly (9) from body (14).
9. Remove ring spacers (8) and (10) from diaphragm assembly and discard diaphragm assembly.
10. Secure the three diaphragm assembly from the service kit and install the ring spacers (8) and (10) — hexagonal nut on top — making sure that all holes in the diaphragms are aligned with holes in the upper and lower ring spacers. Set the assembly aside.
11. Remove plate (17) and end cap (18) by removing two screws (19). Pull out inner valve assembly.
12. Loosen screws (11), remove seal plate assembly (12) and set aside.
13. Remove gasket (13) and discard. Secure gasket from service kit and place in bottom well of body (14), aligning indents in gasket with holes in body (14).
14. Using a soft hammer, tap out the seat (15) and discard.
15. Secure the seal plate assembly (12) and place in center well of body (14) so that the aspirator tube extends into well nearest the OUT port.
16. Turn body (14) over. Secure seat assembly (15) from kit and insert, brass end first into center well of body (14). Using a wooden dowel, tap until it is seated against the shoulder in the well of the body (14).
17. Secure inner valve assembly (16) from the kit and place into center well of body (14). Tap until it is seated.
18. Secure plate (17) and end cap (18) and place over the inner valve assembly (16), aligning holes in plate (17) and end cap (18) with holes in body (14).
19. Secure to body (14) with two screws (19).
20. Turn body (14) over. Place diaphragm assembly (9) on body, aligning marks made in step 2 and making sure that six holes in diaphragm assembly (9) are aligned with six holes in body (14).
21. Place spring (6) over hex nut in diaphragm assembly (9).
22. Place spring seat (15) over spring (6). The turned down rim should be placed OVER the spring.
23. Using marks made in step 2, align six holes in bonnet assembly (3) with six holes in diaphragm assembly (9). Secure to body (14) with 16 screws (4).
24. Reinstall the relay using installation instructions in the IOM, and refer to the Operation section to place the relay back in service. Place cap nut (1) over the range screw (1A).

Index.	Part No.	Description
1	EB-7057-2	Cap Nut
1 A	EB-8159-18	Range Screw
2	EB-1120	Lock Nut
3	EB-1823-1	Bonnet Assembly
4	EB-1032-30	Screw
5	EB-8058	Spring Seat
6	EB-8060-	Spring
8	EB-7056	Upper Ring Spacer
*9	EB-13272	Diaphragm Assembly
10	EB-13268	Lower Ring Spacer
11	EB-1032-5	Screw
12	EB-7036	Seal Plate
*13	EB-6053	Gasket
14	See Table	Body
*15	EB-15074-1	Seat Assembly
*16	EB-15075-1	Inner Valve Assembly
*16 A	EB-6017	Screen
17	EB-6027	Plate
18	EB-7136	End Cap
19	EB-1032-6	Screw

\*EA-13369 Service Kit Components

### OPTIONS

	STD	E
Ring Spacer	EB-7055	EB-89145-6

Plugged Body	Port Size
EB-14745-8	¼ NPT
EB-14745-9	⅜ NPT
EB-14745-14	½ NPT
EB-14745-17	¼ BSPP
EB-14745-18	⅜ BSPP
EB-14745-19	½ BSPP
EB-14745-21	¼ BSPT
EB-14745-22	⅜ BSPT
EB-14745-23	½ BSPT

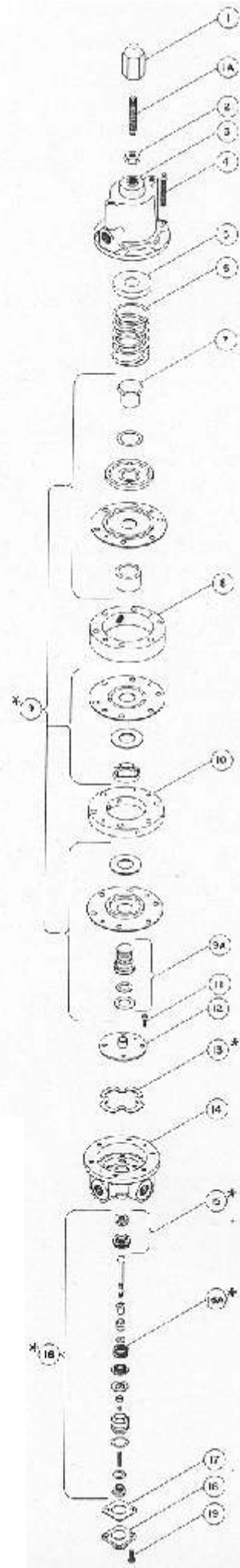

## ADJUSTMENTS

There are no field adjustments required.

## OPERATION

The Model 25 reversing relay has a fixed output pressure as set by the adjusting screw. The addition of a signal to the signal port will reduce the output pressure by the same amount as the signal. For example, if the output pressure was set at 30 PSIG, a 10 PSIG signal would reduce the output by 10 PSIG or 20 PSIG would be the resultant output. If the signal pressure was 30 PSIG, then the output would be zero.

Relieve pressure on range spring before putting relay into service for the first time. To operate, turn the adjusting screw slowly in a clockwise direction until required downstream pressure is obtained. Turned in this direction, the screw compresses the range spring causing increased output pressure. For decreased output pressure, turn the screw counter-clockwise.

## MAINTENANCE

The relay is easily disassembled for the occasional cleaning or removal of foreign matter. Before this is done, however, shut off valve upstream of the relay to prevent escape of air when relay is disassembled. There is no need to remove the relay from the pipe line; remove the two No. 10-32 screws on the bottom of the unit and pull out the inner valve assembly. Wash inner valve assembly with solvent exercising care to avoid

damaging diaphragms and valve fittings. Replace assembly carefully.

The vent hole in the bonnet should be kept clear. A slight flow of air through this hole is necessary for the proper operation of the relay.

The adjusting screw should be lubricated with Moly-cote type "G" grease.

## TROUBLE SHOOTING

PROBLEM	CHECK
Leakage	Body screw tightness Diaphragm
High Bleed	Relief pintle and relief seat for damage or contamination
Difficult to Adjust	Adjusting screw and ball Seal ring lubrication

## REPAIR PARTS LIST

Service Kit EA-12\*36 is available for maintenance of the Model 25 relay.

## LEGAL NOTICE:

The information set forth in the foregoing Installation, Operation and Maintenance Instructions shall not be modified or amended in any respect without prior written consent of Fairchild Industrial Products Company. In addition, the information set forth herein shall be furnished with each product sold incorporating Fairchild's unit as a component thereof.



[www.fairchildproducts.com](http://www.fairchildproducts.com)

IS- 3000025  
Litho in USA  
Rev. F 11/99

