

# FAIRCHILD MODEL 2500A BIAS REVERSING RELAY

## Installation, Operation and Maintenance Instructions

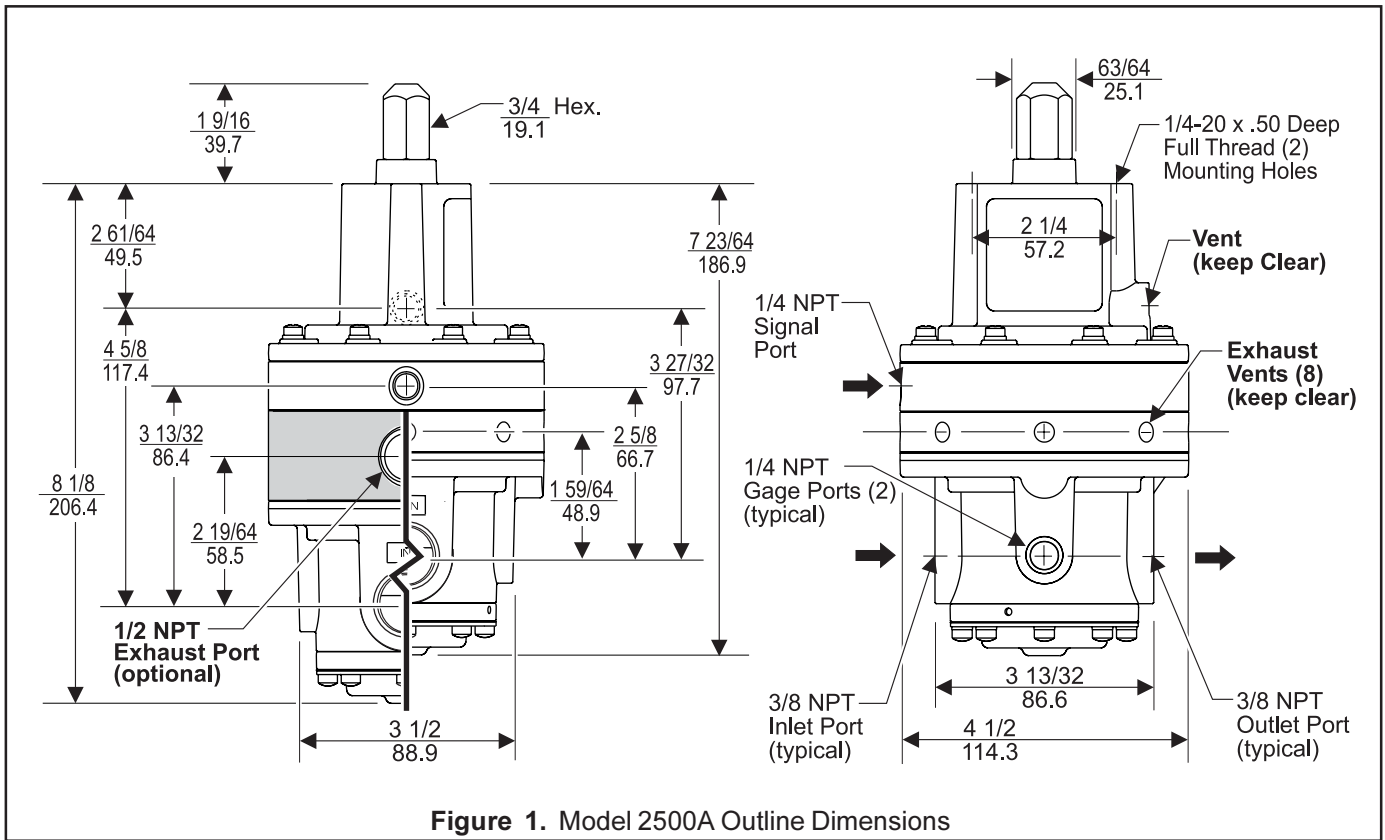

### INSTALLATION

Use the two 1/4-20 tapped holes in the Bonnet to panel mount the Model 2500A. You can mount the relay in any position without affecting its operation.

Clean all pipelines to remove dirt and scale before installation.

Apply a minimum amount of pipe compound to the male threads of the fitting only. **DO NOT use teflon tape as a sealant.** Start with the third thread back and work away from the end of the fitting to avoid contaminating the relay. Install the relay in the air line.

The Inlet and Outlet ports are labeled "In" and "Out". Tighten all connections securely. Avoid undersized fittings that will limit the flow through the relay. For more information, see Figure 1.

**NOTES:** Oil free air must be applied to the relay. Use a filter to remove dirt and entrained liquid in the air line ahead of the relay. If an air line lubricator is used, it **MUST** be located downstream of the relay to avoid interference with performance.

### OPERATION

The Model 2500A provides output pressure that decreases in direct proportion to increases in input signal. To decrease the bias pressure, turn the screw under the Tamper Proof Cap counterclockwise. To increase the bias pressure, turn the screw clockwise. ( $P_o = K - P_s$ ); where  $P_o$  is output pressure,  $K$  is the spring constant, set by the screw, and  $P_s$  is signal pressure. For more information, see Figure 1.

# MAINTENANCE

To clean the Model 2500A, use the following steps:

1. Shut off system pressure to the relay to prevent air from escaping. It is not necessary to remove the relay from the air line.
2. Remove the four Screws and Washers (between ports) from the bottom of unit. For more information, see Figure 2.
3. Remove the Inner Valve Assembly. For more information, see Figure 2.
4. Wash the Inner Valve Assembly with a solvent. Exercise care to prevent damage to diaphragms and valve facings. **Avoid solvents such as acetone, carbon tetrachloride and trichloroethylene.**
5. Replace the assembly carefully. Ensure that the Vent in the exterior part of the Inner Valve Assembly, the Vent in the Bonnet, and the Exhaust Vents in the Spacer Ring are clear. For more information, see Figure 2.

## Troubleshooting

Problem	Source	Solution
Leakage	Bonnet Screws	Tighten the Bonnet Screws.
High Bleed	<ul style="list-style-type: none"> <li>• Relief Valve</li> <li>• Supply Valve</li> <li>• Supply Seat</li> </ul>	<ul style="list-style-type: none"> <li>• If contaminated, clean the source and Body.</li> </ul>
	<ul style="list-style-type: none"> <li>• Diaphragm Assembly</li> </ul>	<ul style="list-style-type: none"> <li>• If damaged, install the service kit.</li> </ul>

**NOTE:** If the standard maintenance procedure does not correct the problem, install the appropriate service kit.

<b>Standard</b>	<b>Tapped Exhaust</b>
<b>• 19551-1</b>	<b>• 19551-1E</b>

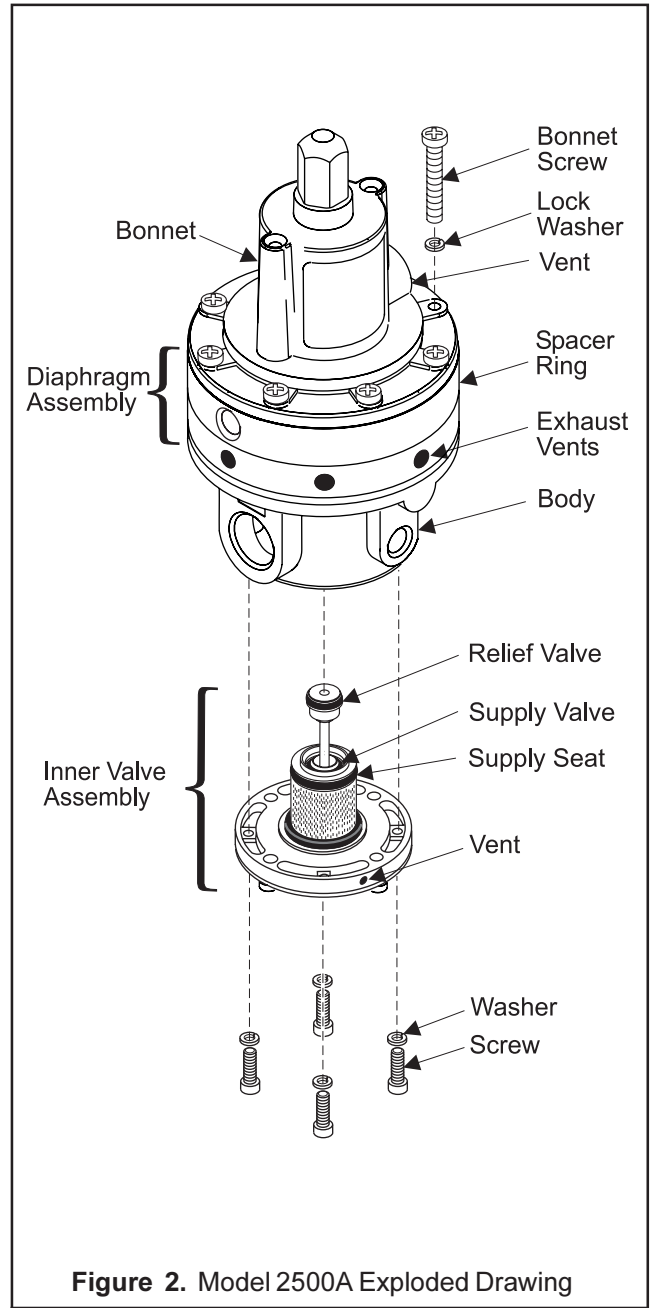

Figure 2. Model 2500A Exploded Drawing



ISO 9001:2000  
Certified

ISO 9001:2000  
FM NO. 25571



IS-3002500A  
Litho in USA  
A 06/07

# **P.S.I. Supplies Pty Ltd.**

Installation and Maintenance Instructions for:

## **Fairchild Model 2500A Bias Reversing Relay**

For further advice or assistance please contact:

[www.psisupplies.com.au](http://www.psisupplies.com.au)

Ph: +61 3 9899 6444

Email: [sales@psisupplies.com.au](mailto:sales@psisupplies.com.au)