

FAIRCHILD MODEL 4500A PNEUMATIC VOLUME BOOSTER

Installation, Operation and Maintenance Instructions

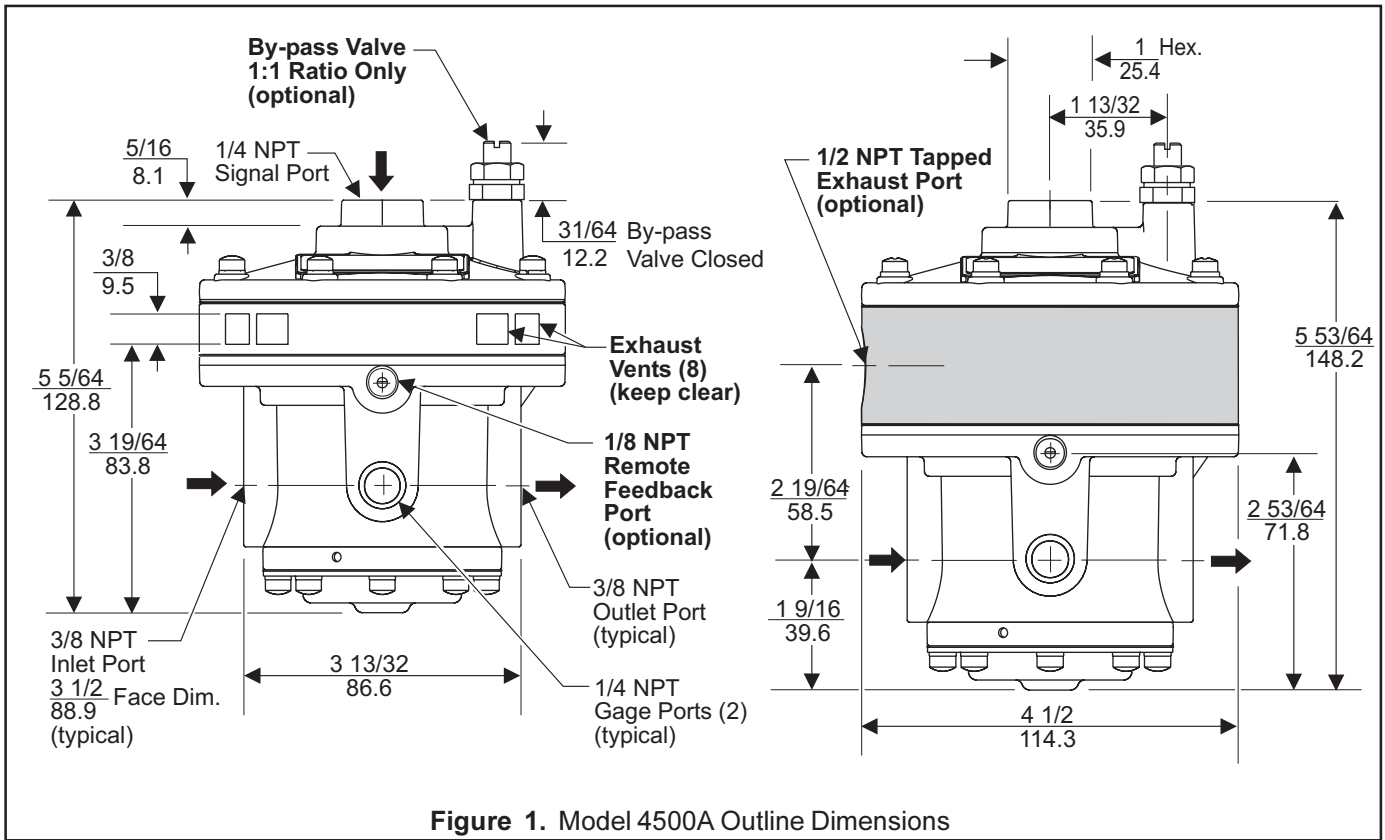

INSTALLATION

You can mount the booster in any position without affecting its operation.

Clean all pipelines to remove dirt and scale before installation.

Apply a minimum amount of pipe compound to the male threads of the fitting only. **Do Not use teflon tape as a sealant.** Start with the third thread back and work away from the end of the fitting to avoid contaminating the booster. Install the booster in the air line.

The Inlet and Outlet ports are labeled "In" and "Out". Tighten all connections securely. Avoid undersized fittings that will limit the flow through the booster. For more information, see Figure 1.

OPERATION

The Model 4500A reproduces a pneumatic signal in a 1:1 ratio or in multiplying or dividing ratios. ($P_o = P_s \times R$); where P_o is output pressure, P_s is signal pressure, R is ratio.

NOTES: Oil free air must be applied to the booster. Use a filter to remove dirt and entrained liquid in the air line ahead of the booster. If an air line lubricator is used, it **MUST** be located downstream of the booster to avoid interference with performance.

MAINTENANCE

To clean the Model 4500A, use the following steps:

1. Shut off system pressure to the booster to prevent air from escaping. It is not necessary to remove the booster from the air line.
2. Remove the four Screws and Washers (between ports) from the bottom of the unit. For more information, see Figure 2.
3. Remove the Inner Valve Assembly. For more information, see Figure 2.
4. Wash the Inner Valve Assembly with a solvent. Exercise care to prevent damage to diaphragms and valve facings. **Avoid solvents such as acetone, carbon tetrachloride and trichloroethylene.**
5. Replace the assembly carefully. Ensure that the Vent in the exterior part of the Inner Valve Assembly and the Exhaust vents in the Spacer Ring are clear. For more information, see Figure 2.

Troubleshooting

Problem	Source	Solution
Leakage	Bonnet Screws	Tighten the Bonnet Screws.
High Bleed	<ul style="list-style-type: none"> • Relief Valve • Supply Valve • Supply Seat 	<ul style="list-style-type: none"> • If contaminated, clean the source and Body.
	<ul style="list-style-type: none"> • Diaphragm Assembly 	<ul style="list-style-type: none"> • If damaged, install the service kit.

NOTE: If the standard maintenance procedure does not correct the problem, install the appropriate service kit.

Standard	Tapped Exhaust	Ratio
• 19549-1	• 19549-1E	• 1:1 & By-pass Option (I)
• 19549-2	• 19549-2E	• 1:2
• 19549-3	• 19549-3E	• 1:3
• 19549-4	• 19549-4E	• 2:1
• 19549-5	• 19549-5E	• 3:1

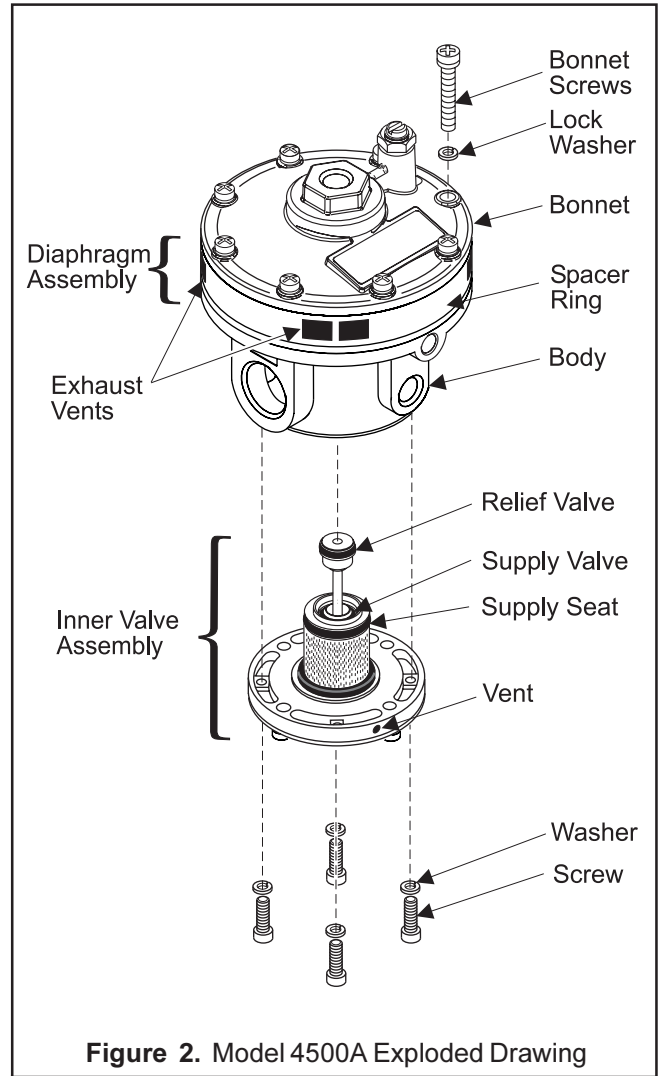

Figure 2. Model 4500A Exploded Drawing

LEGAL NOTICE:

The information set forth in the foregoing Installation, Operation and Maintenance Instructions shall not be modified or amended in any respect without prior written consent of Fairchild Industrial Products Company. In addition, the information set forth herein shall be furnished with each product sold incorporating Fairchild's unit as a component thereof.



ISO 9001:2000
Certified

FAIRCHILD
precision pneumatic & motion control

IS-2004500A
Litho in USA
Rev. F 12/03

