

# FAIRCHILD T5221 ELECTRO-PNEUMATIC ADJUSTABLE GAIN TRANSDUCER Installation Instructions

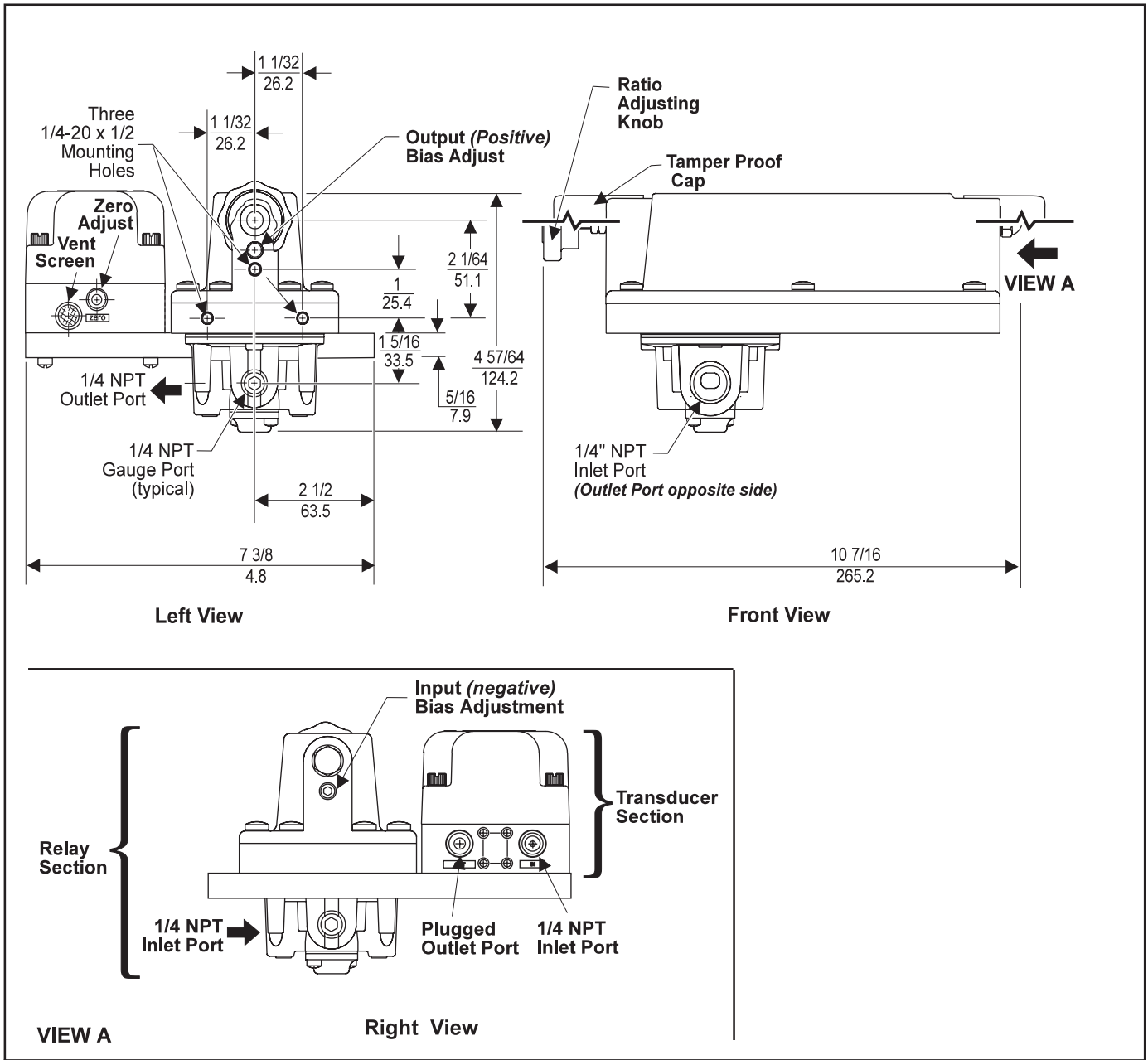

Figure 1. T5221 Outline Dimensions.

## INSTALLATION

The Model T5221 can be mounted directly onto a flat surface using the three 1/4"-20 x 1/2" mounting holes in

the Ratio Relay. For more information, see Figure 1. "T5221 Outline Dimensions" above.

**Installation (continued)**

The Model T5221 can be mounted on a 2" Pipe using a mounting bracket and pipe clamp supplied

in Mounting Kit 15307-1. For more information, see Figure 2, "Mounting Kit 15307-1" below.

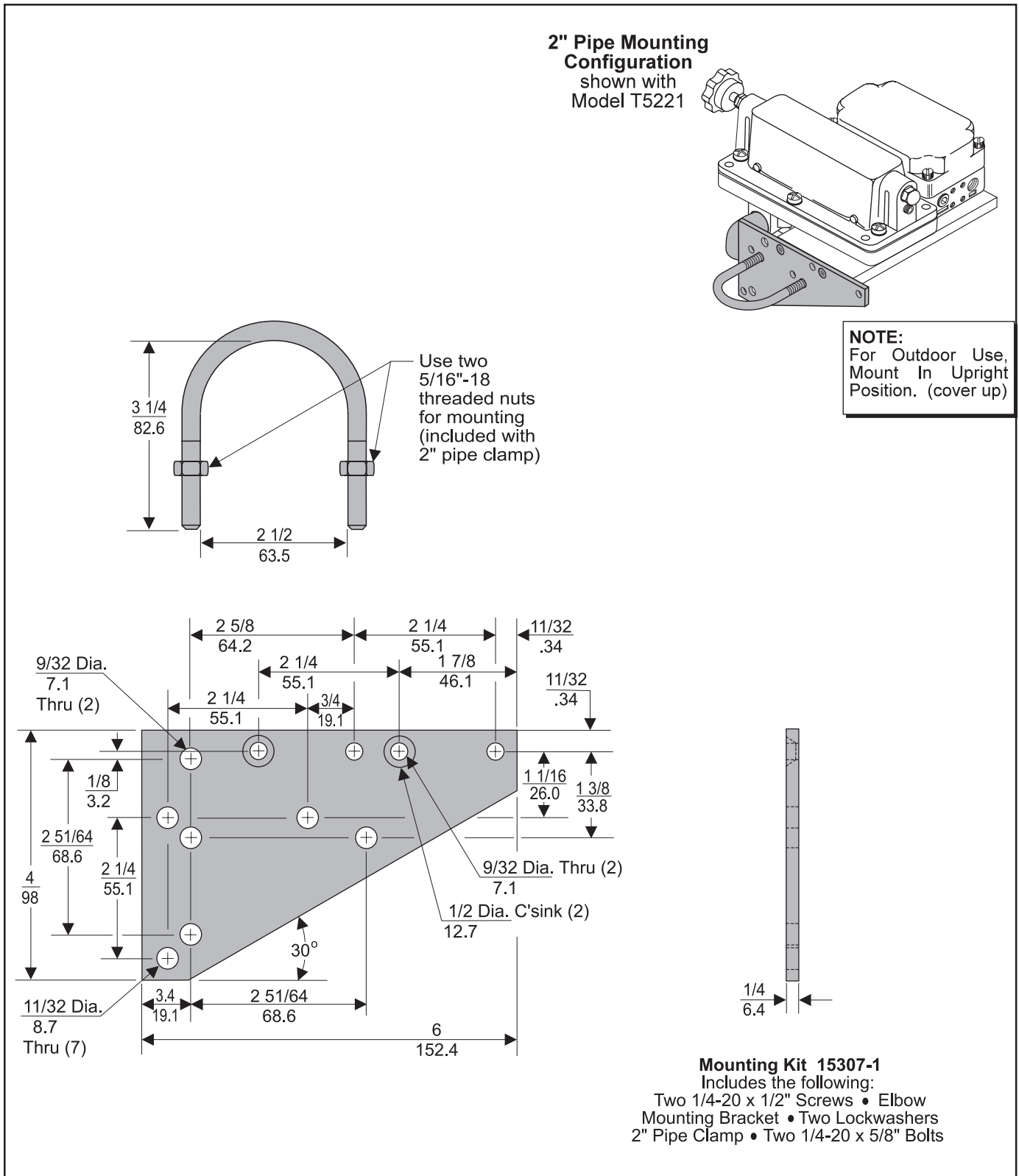

**Figure 2. Mounting Kit 15307-1. (Included with Unit)**

## Pneumatic Connections

Clean all pipelines to remove dirt and scale before installation.

Apply a minimum amount of pipe compound to the male threads of the fitting only. **Do Not use teflon tape as a sealant.** Start with the third thread back and work away from the end of the fitting to avoid the possibility of contaminating the transducer. Install the transducer in the air line.

The inlet and outlet ports are labeled on the end of the transducer. Tighten connections securely. Avoid undersized fittings that will limit the flow through the transducer and cause a pressure drop down stream. Apply 20 psig to the transducer inlet. Outlet port should be plugged. Apply up to 250 psig to the inlet port of the booster. For more information, see VIEW A on page 1, in Figure 1. "T5221 Outline Dimensions".

**NOTES:** Instrument quality air, per ISA Standards D7.3-1981, is required. Use a filter to remove dirt and liquid in the air line ahead of the transducer for correct performance. If an air line lubricator is used, it **MUST** be located downstream, beyond the transducer.

The user is responsible for insuring that the environment in which the unit will be installed, and the operating gas, are compatible with the materials in the transducer.

## Electric Connection

For the T5221 Transducer, make connections to the Terminal Block through a 1/2 NPT Conduit Connector (not supplied) and a plastic sleeve as shown below in Figure 3. "Electrical Connections".

**NOTE:** The T5221 should be wired in accordance with the wiring diagram inside of cover.

## Wiring in Hazardous Areas

Wiring in hazardous areas should be performed in accordance with the Table 1. and any local codes that apply.

Country	Agency	Code
U.S.	FM	ANSI/ISARP 12.6 & ANSI/NFPA 70
Canada	CSA	CEC Part 1

## Intrinsically Safe Connections

Refer to the latest revision of the indicated drawing.

Underwriting Group	Drawing Number
FM (Factory Mutual)	EC-14007
CSA (Canadian Standards)	EC-16097

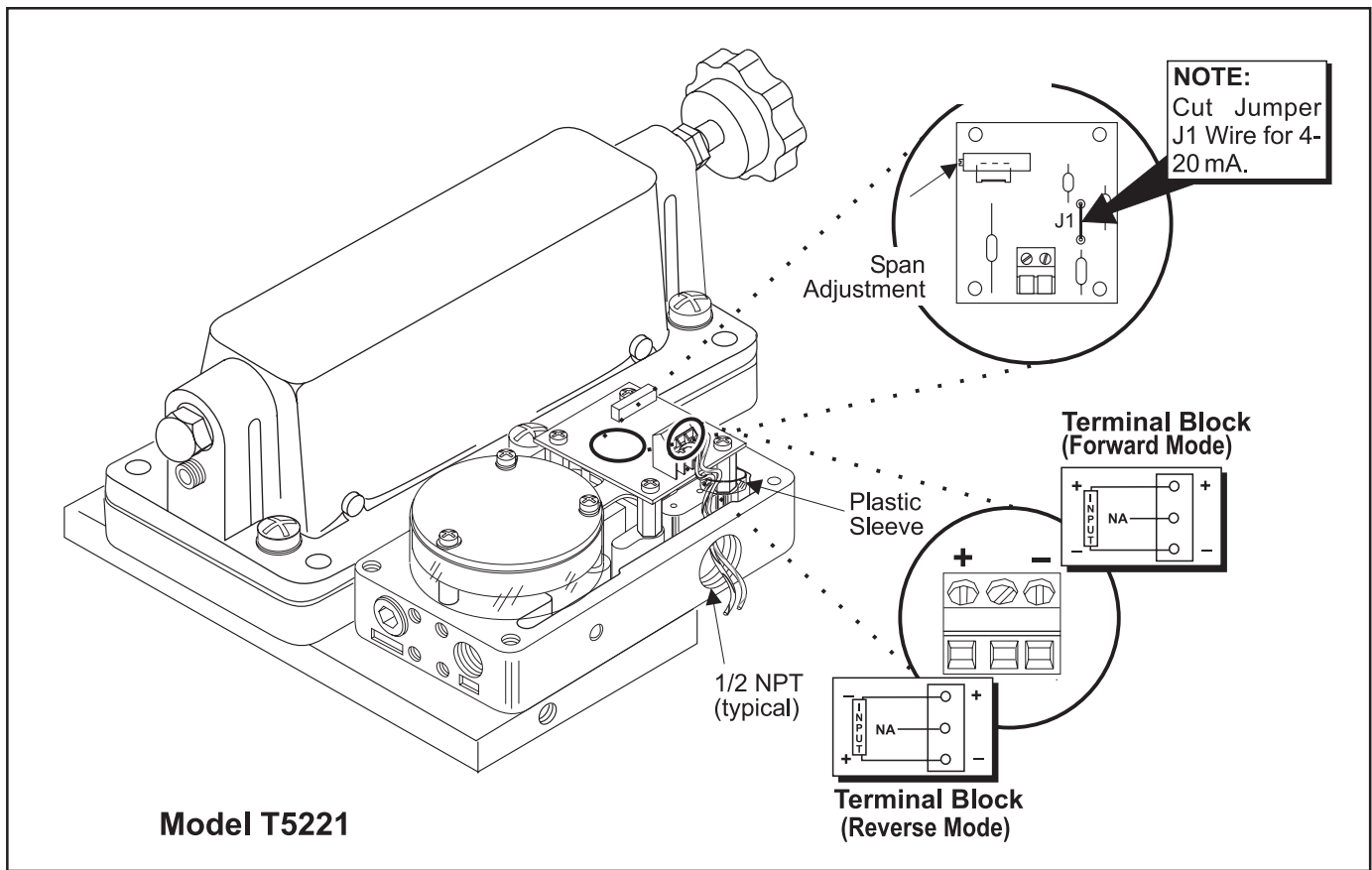

Figure 3. Electrical Connections.

# **P.S.I. Supplies Pty Ltd.**

Installation and Maintenance Instructions for:

## **Fairchild Model T5221 Electro-Pneumatic Adjustable Gain Transducer**

For further advice or assistance please contact:

[www.psisupplies.com.au](http://www.psisupplies.com.au)

Ph: +61 3 9899 6444

Email: [sales@psisupplies.com.au](mailto:sales@psisupplies.com.au)