

# FAIRCHILD T8000 STANDARD RANGE MINIATURE TWO-WIRE, P/I PRESSURE TRANSDUCER Installation Instructions

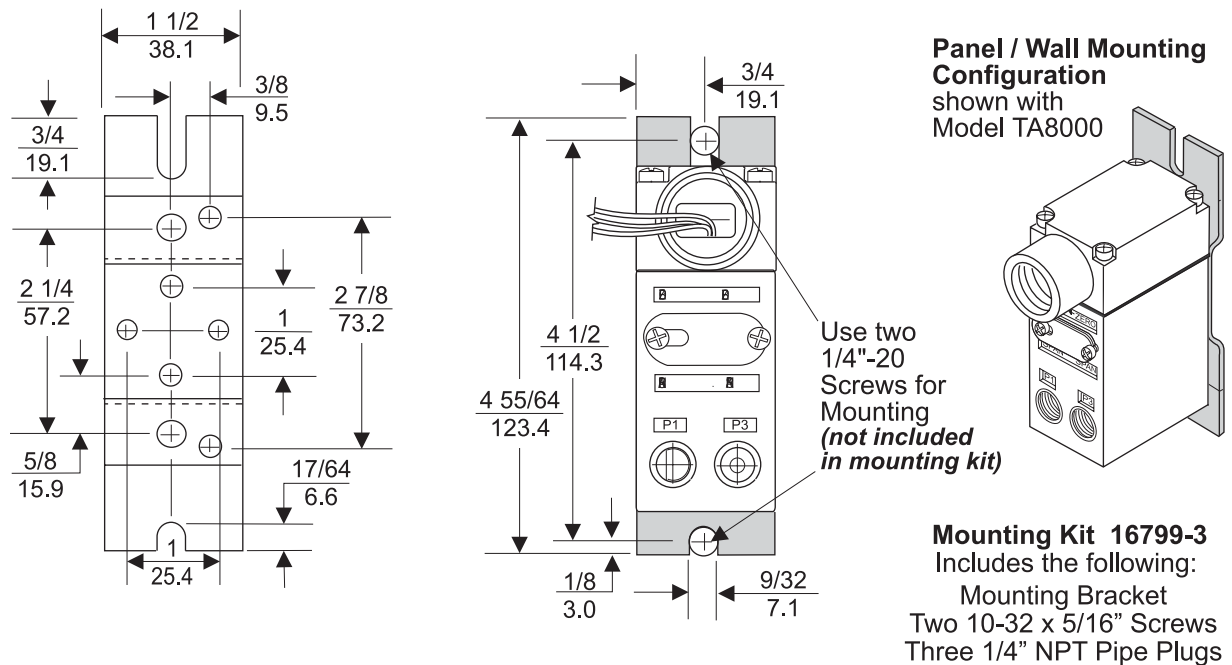
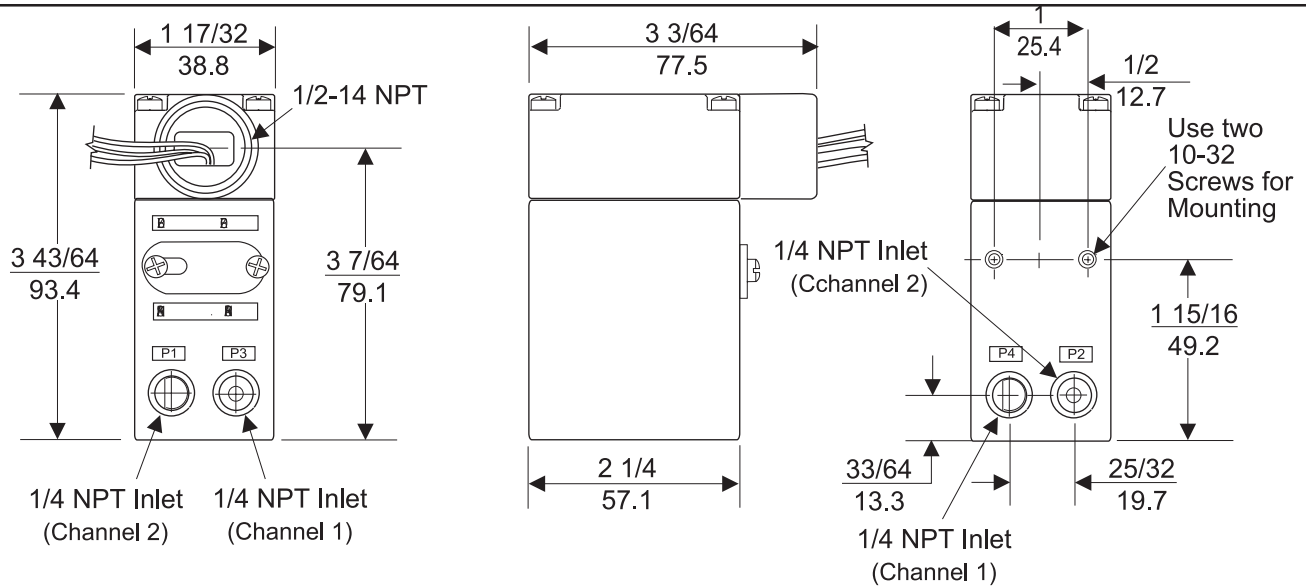

Figure 2. Mounting Kit 16799-3 (Included with unit)

## INSTALLATION

Use Mounting Kit 16799-3 with two 10-32 tapped mounting holes, included with the unit, to mount the Model T8000 Series on a flat surface. Remove the break-away tabs on the mounting plate when used with pipe clamps. For more information, see Figure 2.

A DIN Rail Mounting Kit 16893, is available to install the unit on DIN rails. This mounting kit is included with the unit. For more information, see Figure 6. Use Mounting Kit 19254-1 to install the unit on a 2" pipe. For more information, see Figure 7.

**LEGAL NOTICE:** The information set forth in the foregoing Installation Instructions shall not be modified or amended in any respect without prior written consent of Fairchild Industrial Products Company. In addition, the information set forth herein shall be furnished with each product sold incorporating Fairchild's unit as a component thereof.

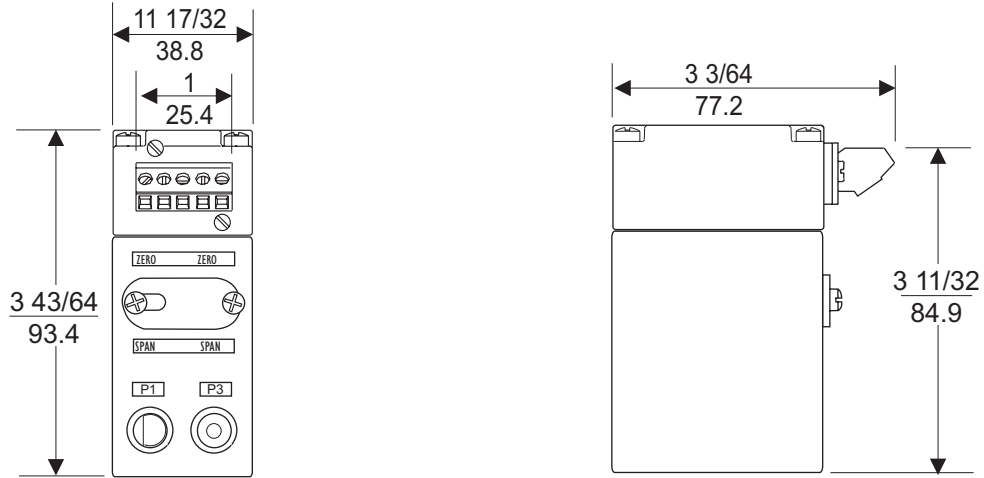

Figure 3. Model TT8000 Outline Dimensions

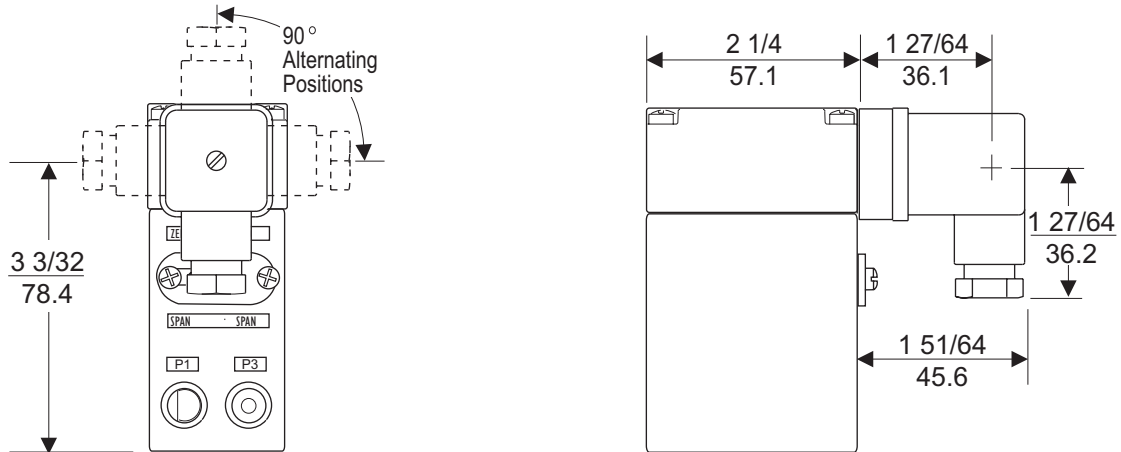

Figure 4. Model TD8000 Outline Dimensions

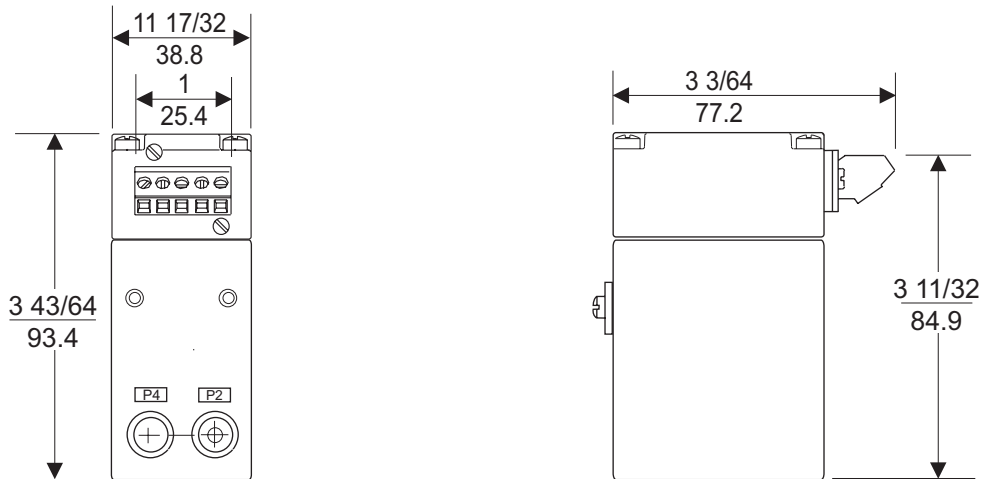
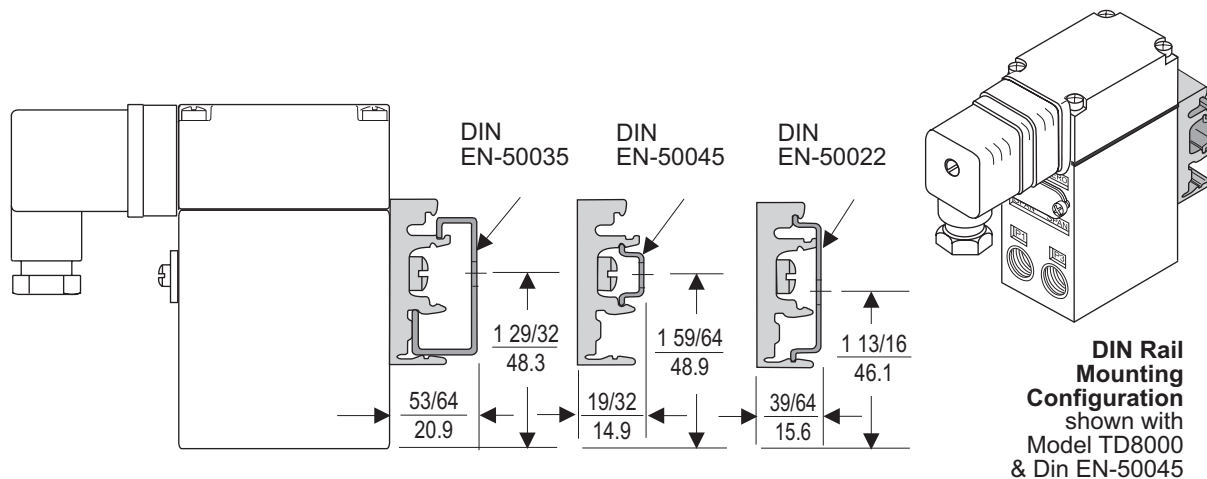
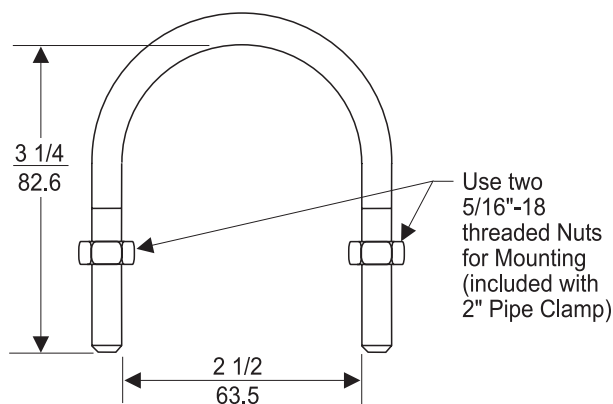

Figure 5. Model TR8000 Outline Dimensions.

NOTE: The TR8000 Transducer is designed to use the TR Rack Kit. Physical construction is the same as the TT8000 (Terminal Block) unit with one exception; the terminal block is located on the back. For more information, see Figure 5.



**Figure 6. DIN Rail Mounting Kit 16893. (Included with unit)**



**2" Pipe Mounting Configuration**  
shown with Model TT8000

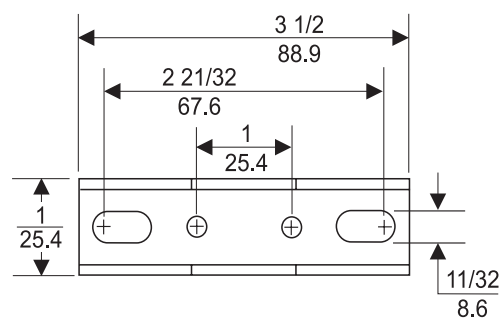
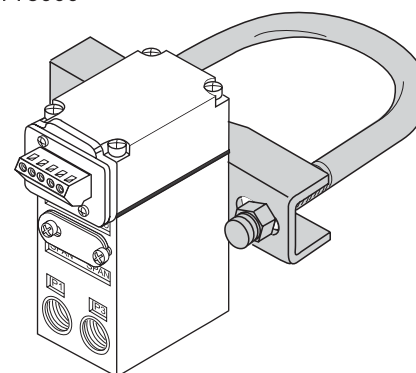

**Mounting Kit 19254-1**  
includes the following:  
Mounting Bracket • 2" Pipe Clamp  
Two 10-32 x 5/16" Screws

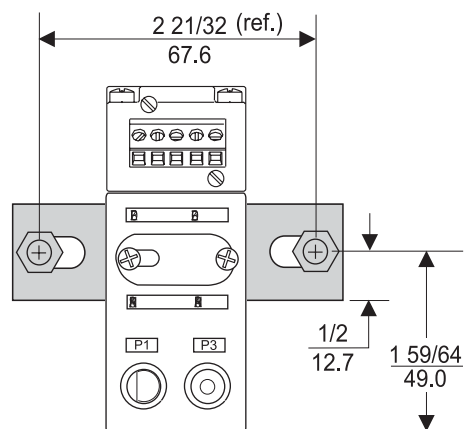

**Figure 7. Optional Mounting Kit 19254-1. (Sold separately)**

## Pneumatic Connections

Clean all pipelines to remove dirt and scale before installation.

Apply a minimum amount of pipe compound to the male threads of the fitting only. **Do Not use teflon tape as a sealant.** Start with the third thread back and work away from the end of the fitting to avoid contaminating the transducer. Install the transducer in the air line.

The inlet ports are labeled on the ends of the transducer. For more information, see Figure 1. Tighten connections securely.

## Electrical Connections

Make connections to the Terminal Block, Conduit Connector, or the DIN Connector as shown in Figure 8.

- Wiring in Hazardous Areas

Wiring in hazardous areas should be performed in accordance with Tables 1 and 2 and any local codes that apply.

Country	Agency	Code
U.S. Canada	FM CSA	ANSI/ISARP 12.6 & ANSI/NFPA 70 CEC Part 1

Underwriting Group	Drawing Number
FM (Factory Mutual) CSA (Canadian Standards)	EC-18601 EC-18600

- Two-wire Transmission System

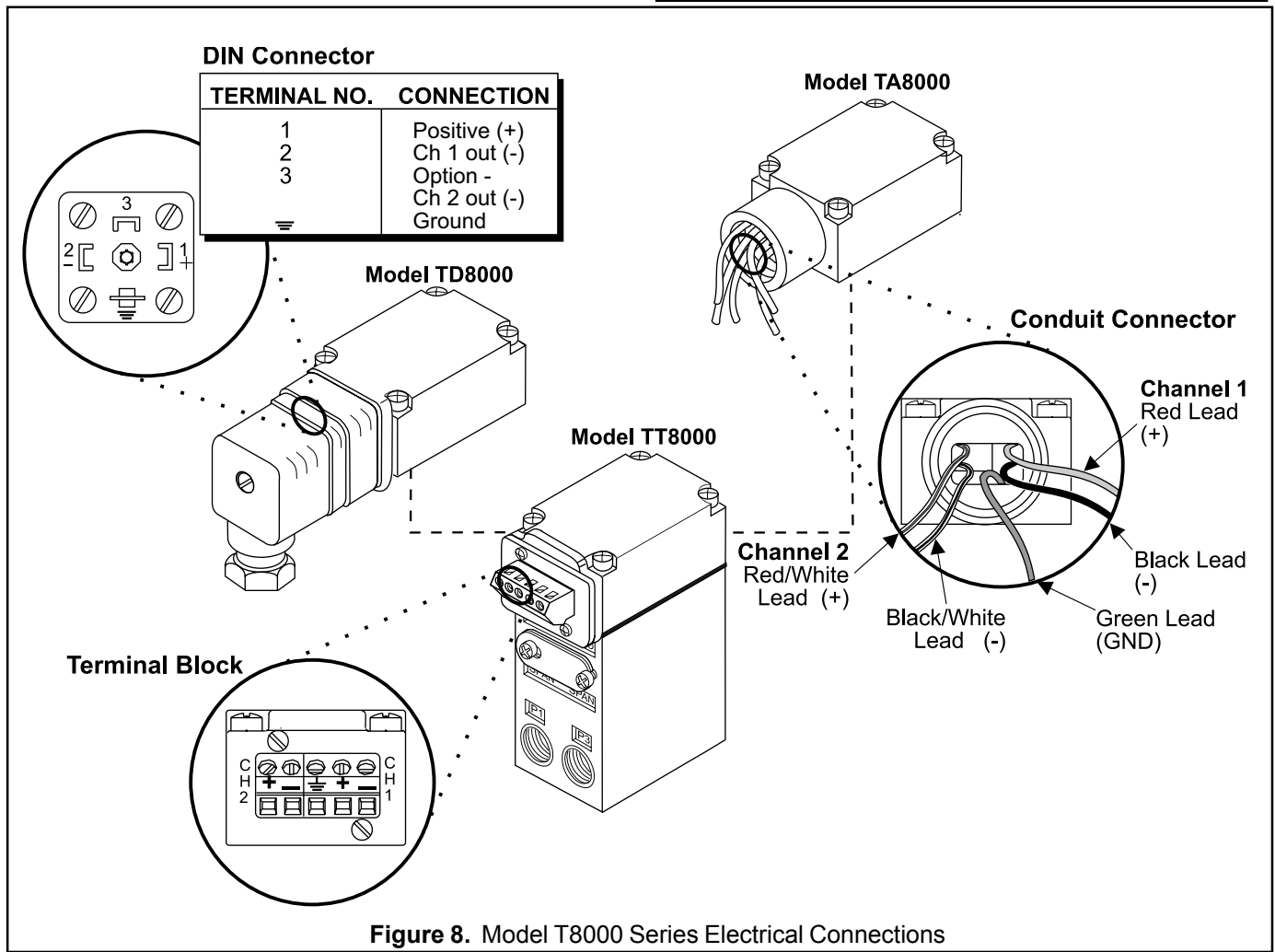
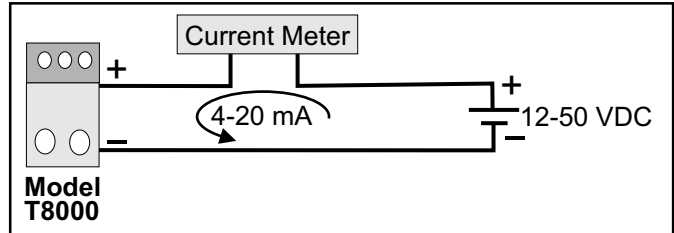

# **P.S.I. Supplies Pty Ltd.**

Installation and Maintenance Instructions for:

**Fairchild Model T8000 Standard Range Miniature Two-Wire, P/I Pressure Transducer**

For further advice or assistance please contact:

[www.psisupplies.com.au](http://www.psisupplies.com.au)

Ph: +61 3 9899 6444

Email: [sales@psisupplies.com.au](mailto:sales@psisupplies.com.au)