

FAIRCHILD TXI7800/TXI7850 EXPLOSION-PROOF I/P TRANSDUCERS

Installation, Operation and Maintenance Instructions

Figure 2. TXI7800/TXI7850 Outline Dimensions.

Standard Range Unit

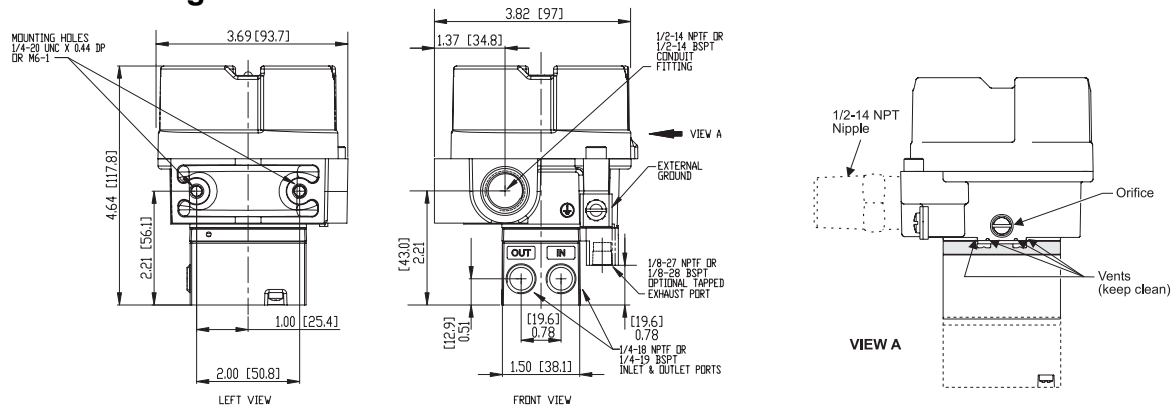

Extended Range Unit

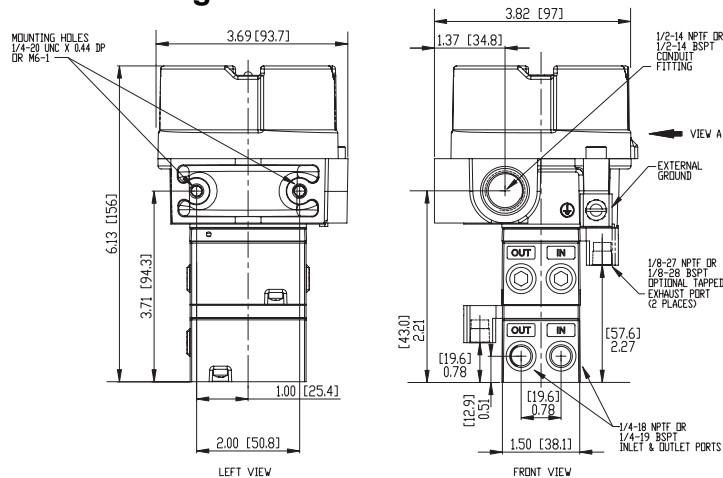

Materials of Construction

Body and Housing	Cromate Treated Aluminum
Orifice	Aluminum and Sapphire
Trim	Stainless Steel, Brass and Zinc Plated Steel
Sintered Elements	Stainless Steel
Elastomers	Nitrile
Finish	Epoxy Powder Coating

NOTE: Unused IN and OUT Ports are plugged.

GENERAL INFORMATION

The Model TXI7800/TXI7850 Explosion-Proof I/P Transducer transmits a pneumatic signal which is linearly proportional to a DC input signal from electronic control devices. The Transducer uses low powered microelectronics and pressure feedback control to provide a stable, accurate pneumatic output for the operation of valve actuators.

INSTALLATION

The Model TXI7800/TXI7850 can be mounted directly onto a flat surface using the two tapped mounting holes in the mounting face of the housing. For more information, see Figure 2.

TXI7800/TXI7850, Installation with the "N" Option.

NOTE: For Hazardous Location in Potentially Explosive Atmosphere Installations

1. Tapped exhaust required for installation in Class 1, Division 2/Zone 2 (European Union) classified locations with group D/Group IIA (European Union) gases such as Natural Gas and Methane-Industrial as the pressure supply medium.
2. The explosion-proof pipe nipple seal (N option) supplied with this unit is an integral component of the design safety of this version and must not be removed. Use caution to avoid marring the threads on the pipe nipple which voids the explosion-proof integrity of the device.
3. Gases used as the pressure supply medium in hazardous location applications must be compatible with the elastomer indicated in Materials of Construction.

A mounting Kit is available to mount the TXI7800/TXI7850 on a flat surface or on a 2" pipe. For more information, see Figure 3.

MAINTENANCE

To clean the Orifice, use the following procedure:

1. Shut off the valve that is supplying air to transducer. It is not necessary to remove the Transducer from the air line.
2. Remove the Orifice Assembly from the unit. For more detailed information see View A.
3. Clean with alcohol and dry with compressed air.
4. Lubricate O-Rings on Orifice Assembly (4) with silicone grease or equivalent lubricant before reassembling.

NOTES:

Parts must be completely dry before reassembling. If the standard maintenance procedure does not correct the trouble, a service kit containing a replacement diaphragm and orifice assembly is available, see Figure 5.

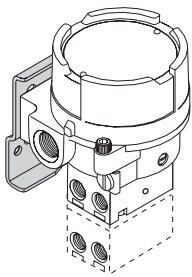

For "U" option BSPT Mounting Kit 19021-2
Includes the following:
 Stainless Steel Mounting Bracket
 Two M6 X 12mm Screws
 2" Pipe Clamp

Panel / Wall Mounting Configuration

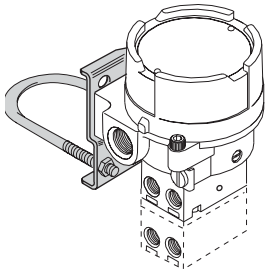

Mounting Kit 19021-1
Includes the following:
 Stainless Steel Mounting Bracket
 Two 1/4-20 x 7/16" Screws
 2" Pipe Clamp

2" Pipe Mounting Configuration

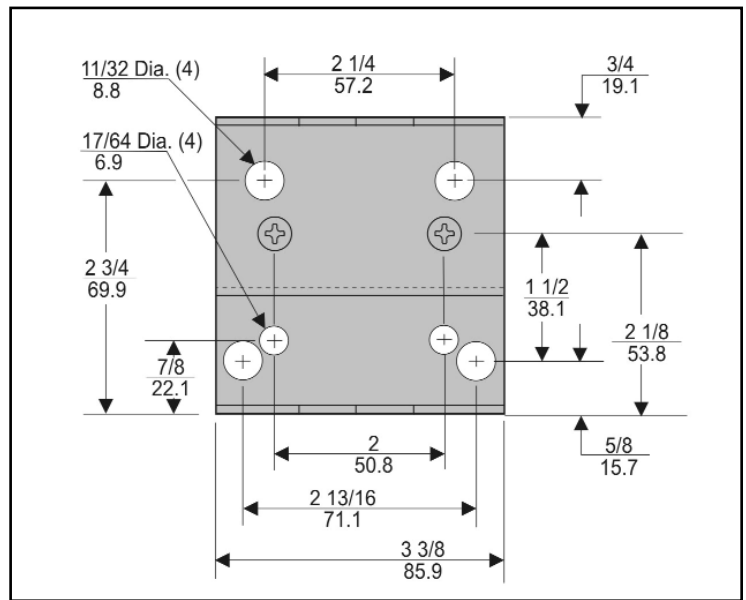

Figure 3. Mounting Kit 19021-1. (Sold Separately)

Pneumatic Connections

Clean all pipelines to remove dirt and scale before installation.

Apply a minimum amount of pipe compound to the male threads of the fitting only. Do not use teflon tape as a sealant. Start with the third thread back and work away from the end of the fitting to avoid the possibility of contaminating the transducer. Install the transducer in the air line. The inlet and outlet ports are labeled on the side of the transducer. Tighten connections securely. Avoid undersized fittings that will limit the flow through the transducer and cause a pressure drop downstream. For detailed information, see Figure 2. "TXI7800/TXI7850 Outline Dimensions" on page 1.

Electric Connections

Make connections to the Terminal Block through the 1/2-14 NPT Conduit Port in the base of the housing as shown below in Figure 4. "Electrical Connections".

NOTE: Instrument quality air, per ISA Standards S7.3-1981, is required. Use a filter, ahead of the transducer, to remove dirt and liquid in the air line. If an air line lubricator is used, it MUST be located downstream, beyond the transducer. The user is responsible for insuring that the environment in which the unit will be installed, and the operating gas, is compatible with the materials in the transducer.

Wiring in Hazardous Areas

Wiring in hazardous areas should be performed in accordance with Table 1. and any local codes that apply.

Table 1. Hazardous Location Wiring Practices		
Country	Agency	Code
U.S.	FM	ANSI/ISA RP 12.6
		ANSI/NFPA70
Canada	CSA	CEC Part1
Europe	ATEX	EN 50 039, EN 60079-14, IEC 60079-14
Australia	SAA	AS/NZS 3000, AS2381.1

Intrinsically Safe Connections

Refer to the latest revision of the indicated drawing.

Table 2. Intrinsically Safe Connections	
Underwriting Group	Drawing Number
FM (Factory Mutual)	EC- 18970
CSA (Canadian Standards Assoc.)	EC- 18971
ATEX	EC- 18972
SAA (Standard Australia Assoc.)	EC- 19271

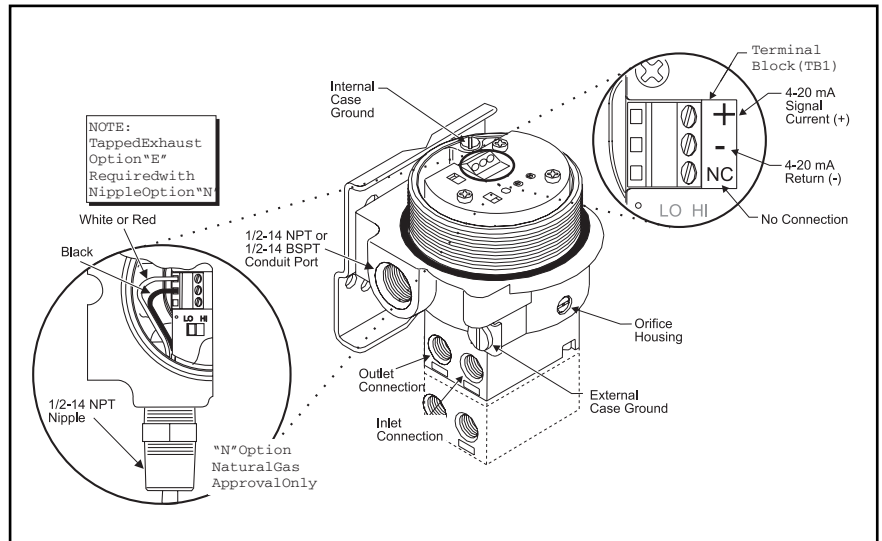

Figure 4. Electrical Connections.

CALIBRATIONS / ADJUSTMENTS

Equipment Required for Calibration:

- Pneumatic Supply capable of delivering up to 150 psig.
- Current Supply capable of delivering up to 30 mA.
- Pressure Gage capable of a digital readout up to 50 psig with an accuracy of .1%.
- Digital Volt Meter capable of a readout up to 30 mA with an accuracy of .02%.

FULL RANGE OPERATION

Lo/Hi Span Adjustment

Set the Lo/Hi Span switch to the required position for needed output and supplied MA input. For more detail information, see Figure 6. "TXI17800/TXI7850 Calibration Configuration".

Forward Acting Mode Adjustment

Set Fwd/Rev Mode switch to Forward position.

Forward Acting Calibration

1. Apply the minimum input signal to the Terminal Block and adjust the Zero screw for minimum output pressure.
2. Apply the maximum input signal to the Terminal Block and adjust the Span screw for maximum output pressure.
3. Repeat steps 1-2 until the desired output range is obtained.

Reverse Acting Mode Adjustment

Set Fwd/Rev Mode switch to the Reverse position

Reverse Acting Calibration

1. Apply the maximum input signal to the Terminal Block and adjust the Zero screw for minimum output pressure.
2. Apply the minimum input signal to the Terminal Block and adjust the Span screw for maximum output pressure.
3. Repeat steps 1-2 until the desired output range is obtained.

SPLIT RANGE OPERATION

Lo/Hi Span Adjustment

Set the Lo/Hi Span switch to the required position for needed output and supplied MA input. For more detail information, see Figure 6 "TXI7800/TXI7850 Calibration Configuration".

Forward Acting Mode Adjustment

Set Fwd/Rev Mode switch to Forward position.

Forward Acting Calibration

1. Apply the minimum input signal to the Terminal Block and adjust the Zero screw for minimum output pressure.
2. Apply the maximum input signal to the Terminal Block and adjust the Span screw for maximum output pressure.
3. Repeat steps 1-2 until the desired output range is obtained.

Reverse Acting Mode Adjustment

Set Fwd/Rev Mode switch to the Reverse position

Reverse Acting Calibration

1. Apply the maximum input signal to the Terminal Block and adjust the Zero screw for minimum output pressure.
2. Apply the minimum input signal to the Terminal Block and adjust the Span screw for maximum output pressure.
3. Repeat steps 1-2 until the desired output range is obtained.

Additional Adjustments

Damping Adjustment

The Damping Adjustment is used so that the transducer can be tuned for optimum response and stability in a particular application. For best performance start Damping Adjustment at maximum adjustment (fully clockwise). Gradually turn counterclockwise until slight oscillation occurs and then turn back clockwise until oscillation is minimized. Turn damping adjustment clockwise to increase damping function.

ATEX Directive- Special Conditions for Sale

The enclosure is manufactured from aluminum alloy. In rare cases, ignition sources due to impact and friction sparks could occur. This shall be considered when the equipment is installed in locations that specifically require Group II, category 1G equipment.

HAZARDOUS AREA SPECIFICATIONS ATEX Directive Nameplates

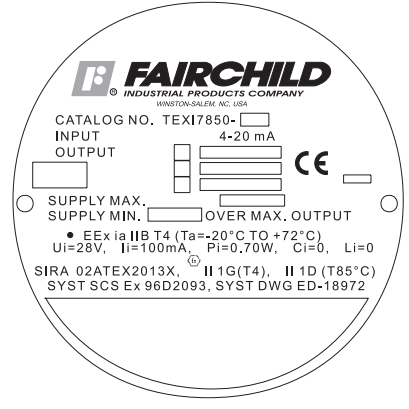
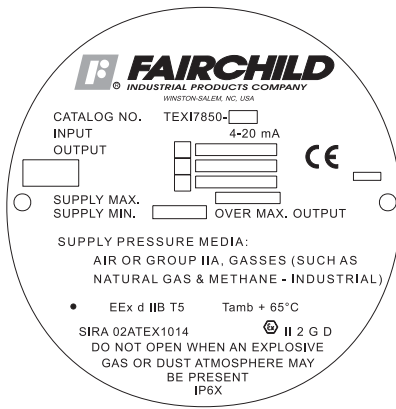
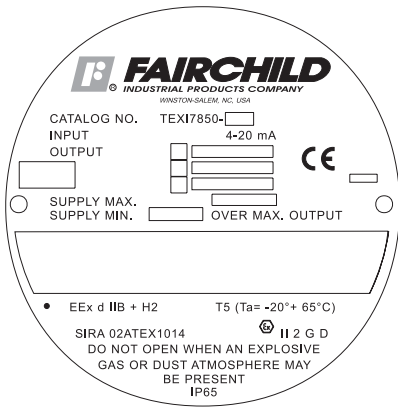

Problem	Solution (check)
No Output	Supply Pressure Clogged Orifice
Leakage	Connections
Low or Improper Span Adjust	Zero and Span Adjust Supply Pressure Low Output Leakage
Erratic Operation	DC Signal Loose Wires or Connections Liquid in Air Supply

WARNING:
Failure of Transducer could result in output pressure increasing to supply pressure possibly causing personal injury or damage to equipment.

Series	Ranges
TEXI/TAXI Kit part no. 19268-1	3-15 psig, [0.2-1.0 Bar], (20-100 Kpa) 3-27 psig, [0.2-1.8 Bar], (20-180 Kpa) 6-30 psig, [0.4-2.0 Bar], (40-200 Kpa)
TCXI/TFX Kit part no. 19268-2	3-15 psig, [0.2-1.0 Bar], (20-100 Kpa) 3-27 psig, [0.2-1.8 Bar], (20-180 Kpa) 6-30 psig, [0.4-2.0 Bar], (40-200 Kpa)
T*XI Kit part no. 19268-14	0-30 psig, [0.0-2.0 Bar], (0-200 Kpa)
T*XI Kit part no. 19268-15	0-60 psig, [0.0-4.0 Bar], (0-400 Kpa)
T*XI Kit part no. 19268-16	0-120 psig, [0.0-8.0 Bar], (0-800 Kpa)

Figure 5.

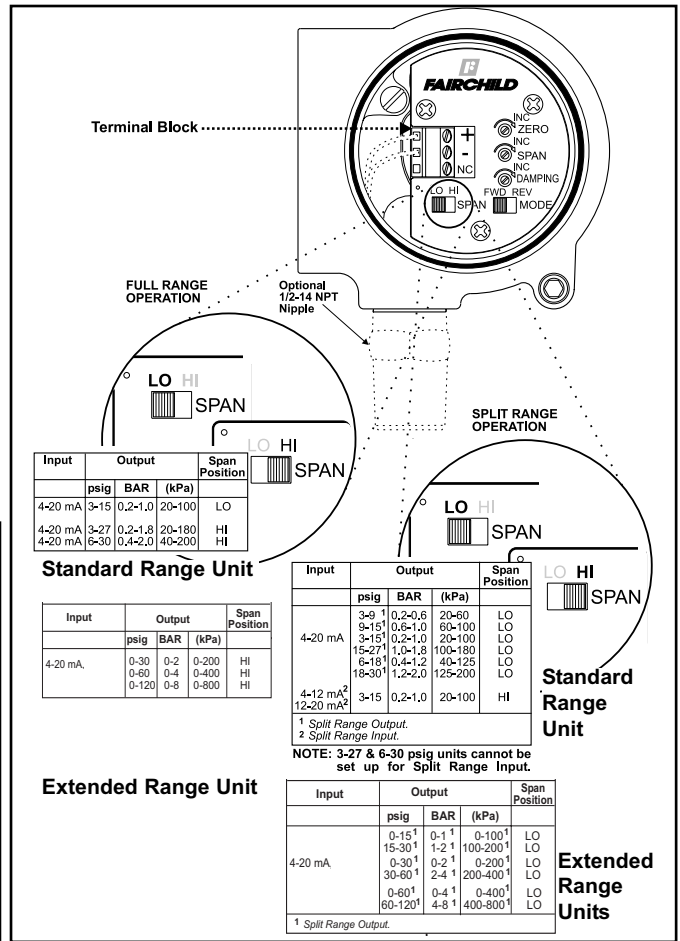

Figure 6.

TXI7800/TXI7850 Calibration Configuration

LEGAL NOTICE:

The information set forth in the foregoing Installation, Operation and Maintenance Instructions shall not be modified or amended in any respect without prior written consent of Fairchild Industrial Products Company. In addition, the information set forth herein shall be furnished with each product sold incorporating Fairchild's unit as a component thereof.



P.S.I. Supplies Pty Ltd.

Installation and Maintenance Instructions for:

Fairchild Model TXI7800/TXI7850 Explosion-Proof I/P Transducer

For further advice or assistance please contact:

www.psisupplies.com.au

Ph: +61 3 9899 6444

Email: sales@psisupplies.com.au